

**CLPT-4818-DW**  
**Compact Mega Top Prep Table**  
**Self-Contained Drawers**



**STANDARD PRODUCT FEATURES**

- High Quality Stainless Steel Construction
- Anodized Aluminum Interior
- Mega Top Pan Capacity for Extra Food Storage
- LED Display Control for Accuracy and Easy Monitoring
- Capillary Tube Metering Device
- 8" Deep, 3/4" Thick, Full Length Removable Cutting Board
- NSF Approved White Polyethylene Board
- Maintains Cabinet Temperature of 32°F to 41°F
- Insulated Hood
- NSF Rated for Use with 6" Deep Pans
- Top Cut-Out Accommodates 1/6 Size Pans (4" deep plastic pans provided)
- Four (4) Fully Removable Drawers
- Each Drawer Accommodates One (1) 1/2 Size Pan and One (1) 1/3 Size Pan
- Easy to Grip Drawer Handle(s)
- Set of Four (4) 4" H Casters, Front Two w/ Locks, Pre-installed on Device
- Gasket-Protecting Retainer
- Self-Contained Rear-Mounted Refrigeration System
- High-Density, Non-CFC Foamed in Place Polyurethane Insulation



This unit is listed to the applicable ETL, CSA and NSF Standards by an approved NRTL. Consult the factory or unit's data plate for approval information.

**ACCESSORIES & OPTIONS (Available at Extra Cost)**

- + Set of Four (4) 6" High Legs
- + Set of Four (4) 6" High Casters
- + Set of Four (4) 2-3/4" High Casters

**AVAILABLE CONFIGURATIONS**

**MODELS**

CLPT-4818-DW Four (4) Drawers

Model	Drawers	Pans (1/6)	Dimensions L x D x H (in.)	Voltage	Amps	NEMA	Cu. Ft.
CLPT-4818-DW	4	18	48.56 x 35.75 x 40*	115/60/1	5.0	5 - 15P	N/A

\*Note: 40 in. height without casters

Approved by \_\_\_\_\_ Date \_\_\_\_\_ Approved by \_\_\_\_\_ Date \_\_\_\_\_

**MODEL - CLPT-4818-DW**

Drawer Models - Mega Top

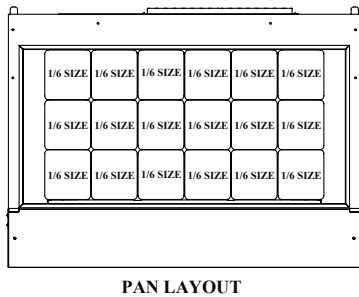
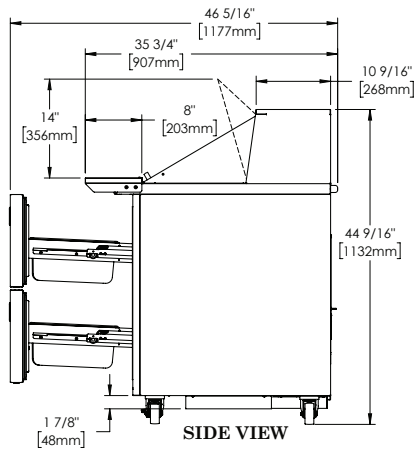
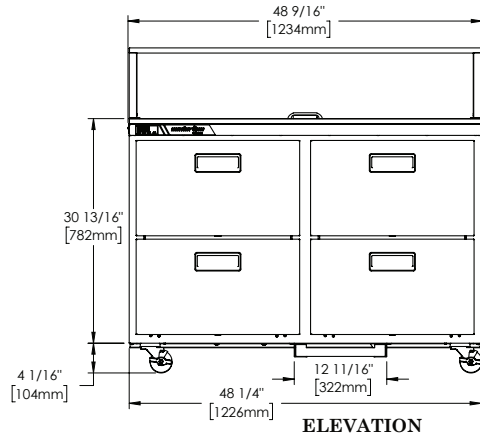

**SPECIFICATIONS**

**CONSTRUCTION, HARDWARE, INSULATION**

Cabinet exterior front, sides, and drawers are constructed of stainless steel. Cabinet interior is constructed of anodized aluminum. 1/6 size plastic pans and set of four (4) 4" high casters are included. Drawers are equipped with a gasket protecting retainer. Both the cabinet and drawers are insulated with an average of 2-3/8" thick high density, non-CFC, foamed in place polyurethane insulation.

**REFRIGERATION SYSTEM**

A rear mounted, self-contained, balanced refrigeration system using environmentally friendly, non-flammable R-450A refrigerant is provided. It features an easy to clean rear facing condenser, capillary tube metering device, and an air-cooled hermetic compressor. A 9' cord and plug is provided. Standard operating temperature is 32°F to 41°F. Energy efficient refrigeration system maintains safe product temperatures. Condenser is located in back of unit for easy maintenance and zero clearance.

**CONTROLLER**

The easy to use electronic digital control is supplied standard. It includes a 3-Digit LED display, and a Fahrenheit or Celsius temperature scale display capability.

**DRAWERS**

Drawer exterior, liner, and frame are constructed of stainless steel. Each drawer has foamed-in place recessed handle for easy grip. Heavy-duty drawers are removable without tools for easy cleaning. Each drawer accommodates one (1) 1/2 size pan and one (1) 1/3 size pan (sold separately).

**WARRANTY**

Both a 6 Year Parts & Labor Warranty and additional 1 Year on Compressor Parts Warranty are supplied standard.

MODELS	CLPT-4818-DW
<b>ELECTRICAL DATA</b>	
Voltage	115/60/1
Full Load Amperes	5.0
<b>REFRIGERATION DATA</b>	
Refrigerant	R-450A
Refrigerant Charge oz.	11.0 (312 gr)
BTU/HR <sup>1</sup>   H.P.	2134   1/4
<b>SHIPPING DATA</b>	
Depth Crated in.	35 (88.9 cm)
Height Crated in.	49 (124.5 cm)
Length Crated in.	53 (134.6 cm)
Volume Crated cu. ft.	52.6 (1490 l)
Net Weight lbs.	326 (147.8 kg)
Gross Weight lbs.	362 (164.2 kg)

NOTES:  
1. BTU/HR based on a 90°F ambient and 20°F evaporator

Equipped with one NEMA 5-15P Plug

