

DESIGNER LINE SANDWICH UNIT

Model: D36N8C

Natural Refrigerant R-290 Model

Designer Line

36" Cutting Top Sandwich Unit Refrigerator with Solid Door - 8 Pans

Stainless steel front, top and end panels and interior.



Options and Accessories

(upcharge and lead times may apply)

Stainless steel back	Casters
Overshelves (single or double)	Rear mounted cutting board
Additional epoxy coated steel shelves	Composite cutting board
Stainless steel shelves	Flat insulated night cover
Door locks	Vision panel lid
Crumb catcher	Modified pan openings

Consult factory for other model configurations, options and accessories.

Project Name:

Model Specified:

Location:

Item No:

Quantity:

AIA #:

SIS #:

Standard Model Features

REFRIGERATION SYSTEM

Performance rated refrigeration system

Natural, environmentally safe, high efficiency R-290 refrigerant¹

Unique air flow distribution allows pan product to maintain 33° - 41°F

Automatic, hot gas condensate evaporator

Non-corrosive, plasticized fin evaporator coil

Easily serviceable, back mounted compressor

CABINET ARCHITECTURE

2" non-CFC polyurethane foam insulation

Smooth, polished chrome door handles

Spring loaded, self closing doors

Magnetic snap in Santoprene™ door gaskets

Heavy duty, epoxy coated steel shelves

19" deep, full length nylon cutting board

Insulated lid

Completely enclosed, vented and removable case back

6" adjustable, stainless steel legs

MODEL FEATURES

Off-cycle defrost

Electronic controller with digital display & hi-low alarm

(8) 1/6 size recessed pans, 4" deep

Removable interior tub below pans

Field rehingeable doors

¹ R-290 refrigerant meets all federal and state regulatory requirements.

Continental[®]
Refrigerator

Toll-Free: 800-523-7138
Phone: 215-244-1400
Fax: 215-244-9579

539 Dunksferry Road
Bensalem, PA 19020
www.continentalrefrigerator.com

APPROVAL:

Model Specifications

DIMENSIONAL DATA

Net Capacity (cubic feet)	10.3 (292 cu l)
1/6 Size Pans (4" deep)	8
Width, Overall (inches)	36 (914 mm)
Depth, Overall (inches) (including cutting board & bumpers)	38 1/4 (972 mm)
Depth, Cutting Board (inches)	19 (483 mm)
Height, Overall (inches) (including 6" legs)	43 1/4 (1099 mm)
Shelf Area (square feet)	4.6 (0.4 sq m)
Number of Shelves	2
Number of Doors	2
Interior Depth (inches)	19 3/8 (492 mm)
Interior Height (inches)	26 1/4 (667 mm)
Interior Width (inches)	32 (813 mm)

REFRIGERANT DATA

Condensing Unit Size (H.P.)	1/5
Capacity (BTU per hour)*	1625

ELECTRICAL DATA

Voltage (International)	115/60/1 (220/50/1)
Total Amps (International)	2.46 (1.85)
10 ft. Cord/Plug [attached] (International)	Yes (No)

SHIPPING DATA

Weight (pounds)	254 (115 kg)
Height - Crated (inches)	43 1/4 (1099 mm)
Width - Crated (inches)	44 (1118 mm)
Depth - Crated (inches)	37 1/4 (946 mm)

* Rating @ +25°F evaporator, 90°F ambient
Figures in parentheses reflect metric equivalents rounded to the nearest whole unit.



Equipped with one NEMA-5-15P Plug
(varies by country)

Continental[®]

Refrigerator

Toll-Free: 800-523-7138
Phone: 215-244-1400
Fax: 215-244-9579

539 Dunksferry Road
Bensalem, PA 19020
www.continentalrefrigerator.com

Due to our continued efforts in developing innovative products, specifications subject to change without notice.



© Copyright 2021. Continental Refrigerator.
A Division of National Refrigeration & Air Conditioning Products, Inc.

Model Plan Views

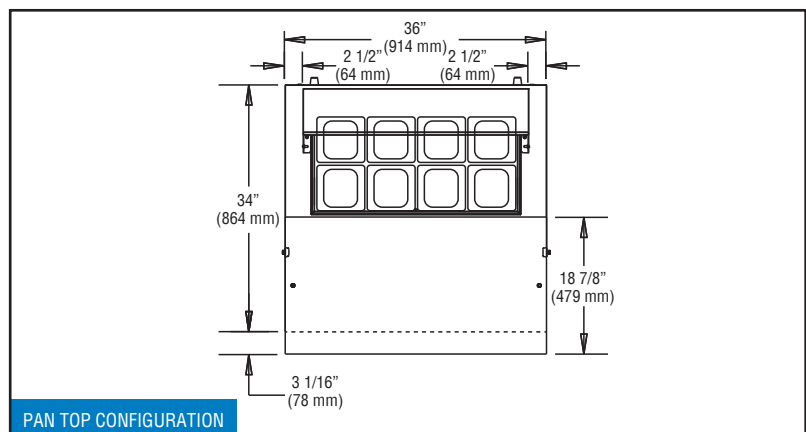
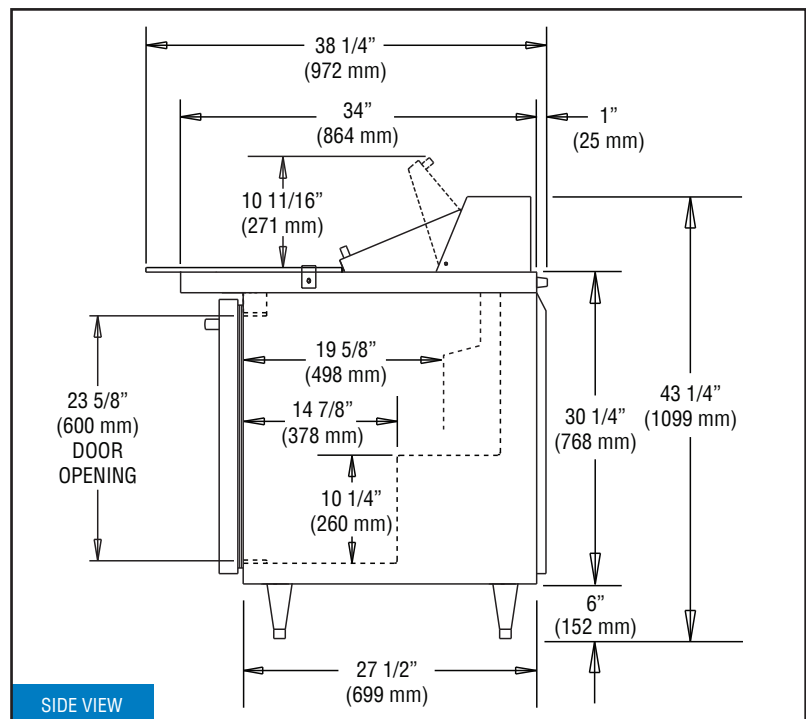
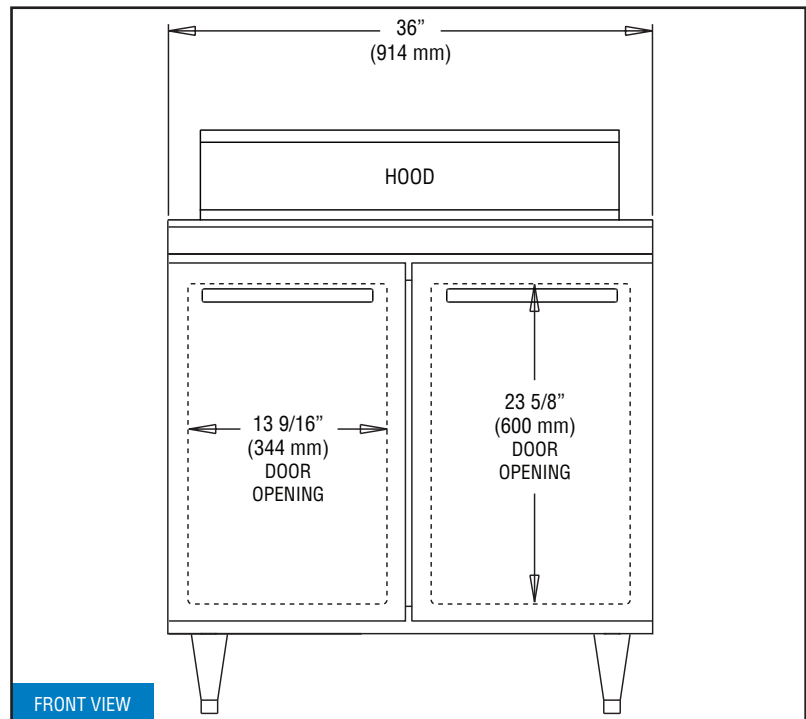

REVISED: 6/9/2022