

# MODULAR CORNER UTILITY FOOD COUNTERS



Item # \_\_\_\_\_ Quantity \_\_\_\_\_

Project \_\_\_\_\_

## MODELS

- MP90-LG     MP90-RG

## M-POWER™ Series

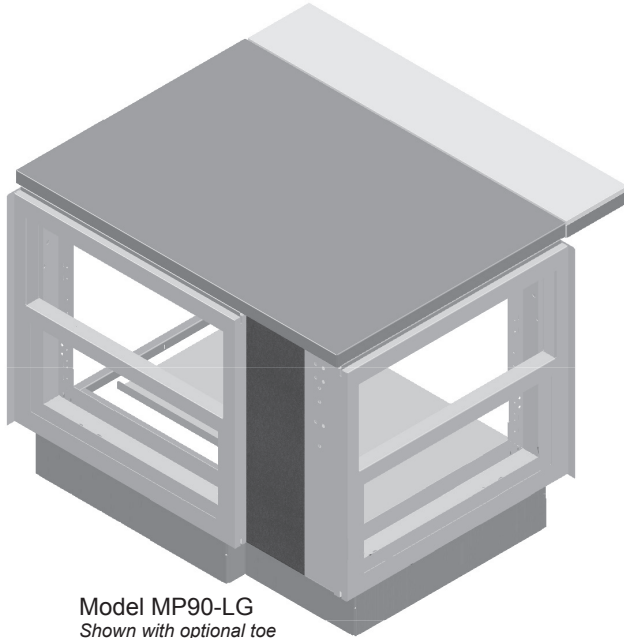

Model MP90-LG  
Shown with optional toe plates and poly work shelf.

- ▶ Durable all-welded stainless steel rigid frame
- ▶ Lightweight, easy mobility with 30" width for doorway passage
- ▶ Heavy duty 14-gauge stainless steel countertop
- ▶ 6" heavy-duty swivel casters, 2 ea. with brake
- ▶ Interchangeable stainless steel or optional laminate exterior panels on exposed portion match or complement any décor
- ▶ Optional 8" work shelf with poly cutting board
- ▶ Optional powder coated toe plate(s), front plate hinged for easy access, available in a variety of colors
- ▶ Patented *TIGHT LINK™* interlocking mechanism, eliminating vertical and horizontal gaps between counters



## OPTIONS & ACCESSORIES

### Counter Height

- 34" high (standard)     32" high

### Electrical (optional)

- 35-15R GFCI duplex outlet wired to 8' cordset with 5-15P plug  
 Empty data box

### Other Options/Accessories

- Stainless steel toe plate(s)  
 Epoxy finish toe plate(s)  
 8" wide poly work shelf with stainless steel frame  
 Grommeted cord passage hole on top

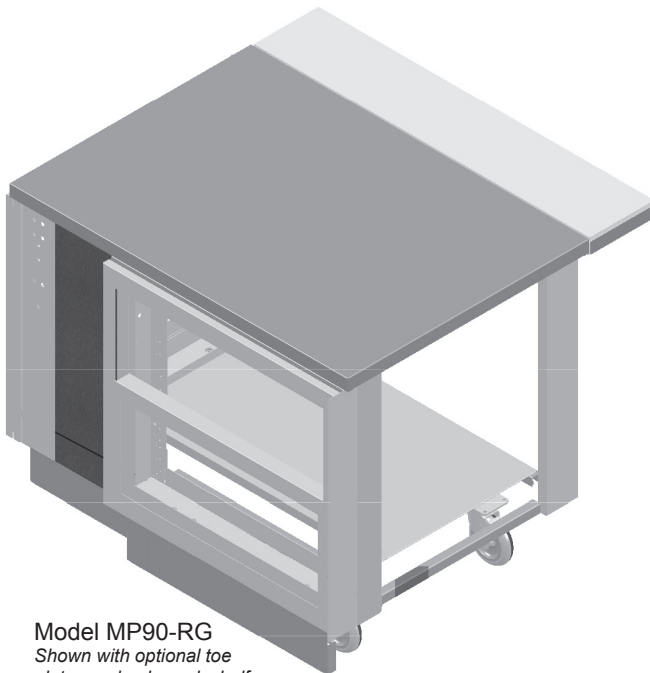

Model MP90-RG  
Shown with optional toe plates and poly work shelf.

### Standard Laminated Panel Finishes

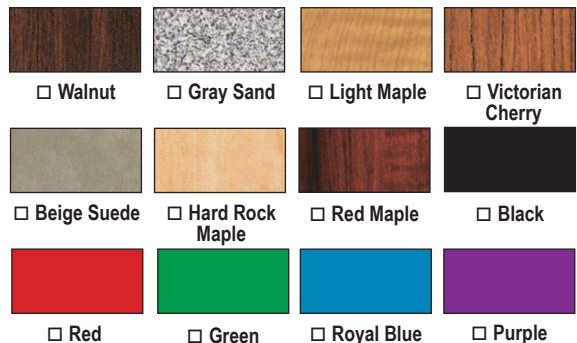

### Other Plastic Laminate Finishes Available

Specify \_\_\_\_\_

# MODULAR CORNER UTILITY FOOD COUNTERS

## MODELS

MP90-LG  
MP90-RG

## M-POWER™ Series

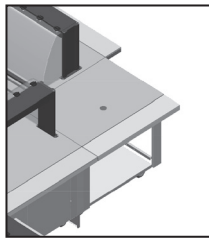

**MP90-LG Configuration**

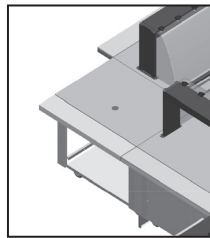

**MP90-RG Configuration**

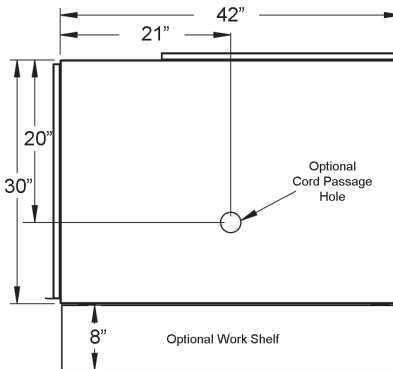

**Plan View ▲**

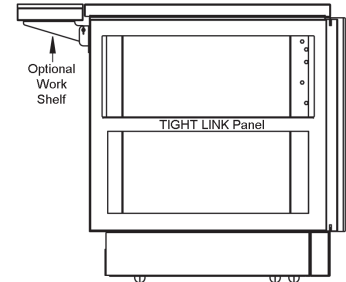

**End View ▲**

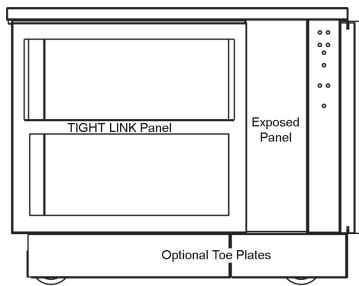

**Front View ▲**

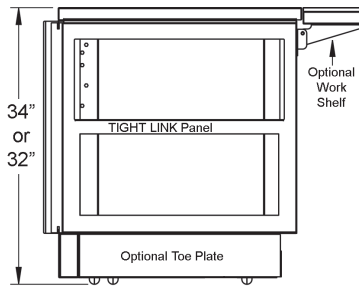

**End View ▲**

**Model MP90-LG**

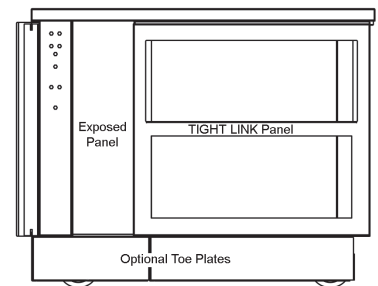

**Front View ▲**

**Model MP90-RG**

### Available Toe Plate Colors

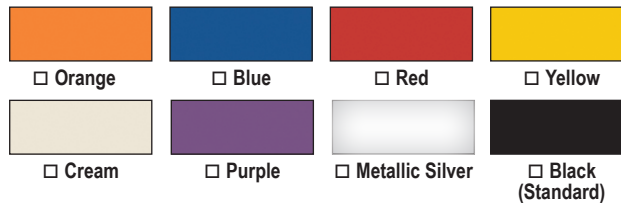

### SPECIFICATIONS

#### General:

Provide Multiteria Model MP90 \_\_\_\_ (-LG, -RG), to be constructed with heavy-duty all-welded stainless steel rigid frame. Countertop to be manufactured with 14-gauge stainless steel with 1½" top turndown. All welds to be ground and polished to provide #4 finish.

#### Body Frame:

Core and shell is 100% stainless steel formed structural box ends, all TIG welded in place, no rivets or fasteners. Body frame is designed to accept TIGHT LINK™ fastening system for multiple counters (2 each panels are included). Base to be furnished with removable stainless steel undershelf. Unit has four ea. 6" heavy-duty swivel casters, two ea. with brake.

#### Customer-Facing Panel:

Exposed stainless steel panel is to be 18-gauge. Optional MDO panel is ¾" thick with standard plastic laminate on front and white laminate interior. Panel is removable for service access. Millwork panel is removable without tools.

#### TIGHT LINK™ System

Patented system features slide-in panels that link adjacent counters together their entire depth and height to eliminate top, front and rear horizontal and vertical gaps between equipment. Linking panels are open to allow mechanical connections to run through adjoining counters without having to cut access holes, reducing the number of building mechanicals required to connect equipment.

#### Limited Warranty:

Core and shell has a lifetime warranty against weld or structural support failure.

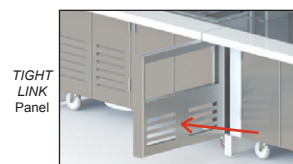

MULTITERIA • 4900 W. ELECTRIC AVENUE • WEST MILWAUKEE, WI 53219

OFFICE: 414.902.6400 • FAX: 414.902.6446 • INFO@MULTITERIAUSA.COM • WWW.MULTITERIAUSA.COM