

BLAST FREEZERS



MADE IN ITALY



Working cycle by time
or by core-probe (included)



ABT-5US



SPECIFICATIONS

	ABT-5US
Dimensions (L x D x H)	33-7/8 x 30-3/4 x 37-3/4
Weight	272 lbs
Trays	5 (26x18")
Max load for trays	55 lbs
Chamber temperature	203/-40 °F
Refrigerant	R404A
Voltage/Frequency/Phase	110V/60Hz/1ph
Load Amps (A)	13 amps
Plug Type	NEMA 5-15P
Material	Stainless Steel
Yield <small>With ambient temperature of +30° C (86°F) loading sample according to EN 17032:2018</small>	149°F / 37.4°F = 57 lbs 149°F / -0.4°F = 35 lbs
Water Evaporation	With manual tray
Shipping Weight	277 Lbs
Shipping Dimensions (in)	37x37x44
Accessories (not included)	Shelf 22.4"x17.5" Casters kit 4"

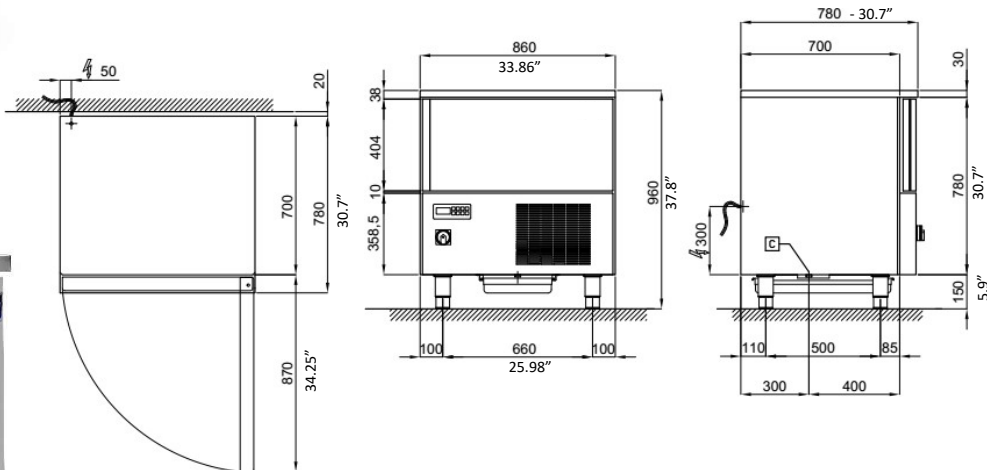

- Defrost system automatic with Pause
- Support for GN1/1 trays and 18x26 trays included
 - Trays pitch 2-1/46" (52.5 mm)
 - Trays not included
- Chilling cycle internal temperature from 158°F to 37.4°F in 90 min approx.
- Freezing cycle internal temperature from 158°F to -0.4°F in 240 min approx.
- Calculate in ambient temperature 89.6°F; Evap -14°F; Cond 113°F and 50% Relative humidity