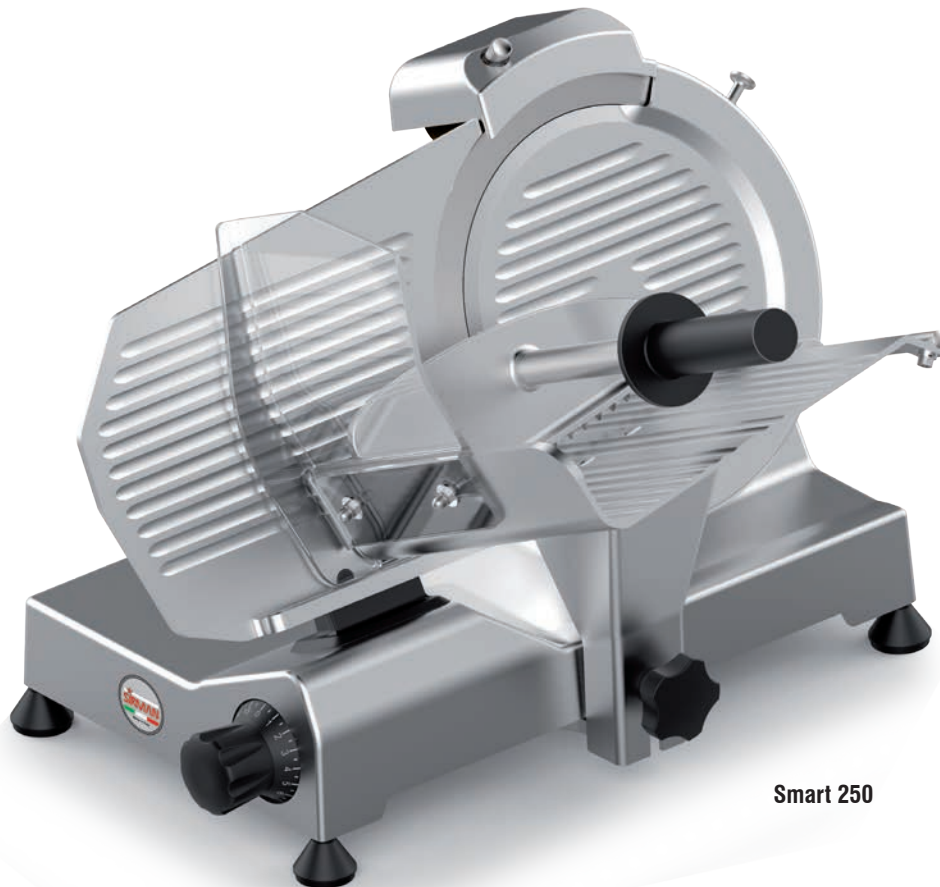

**SMART 250 - 10"****MIRRA 300 C - 12"***Entry slicers***Smart 250**

- High-quality, stylish, lightweight and compact space saving design
- Superior die-cast aluminum construction, Smart 250. Anodized aluminum alloy construction, Mirra 300 C
- Easy to carry for catering needs, Mirra 300 C is the most compact 12" slicer in the market
- The only ones in their class featuring a fan-cooled motor to avoid overheating
- Safety hand guard mounted to the carriage
- The easy, fast breakdown and the increased blade and machine body gap makes cleaning a breeze

Features

Technical:

- The slide shaft is made of ground, chromed steel for a smoother operation.
- The high-quality bushings and ball bearings are self-lubricating.
- The dial thickness control cam system allows for an always precise cut.

Safety:

- A safety cover is placed under the motor and the electrical components.
- The hopper features an exclusive heavy duty plastic protection to keep operator's hand at a safe distance from the blade while operating the slicer.

Sanitary:

- Easy to clean aluminum alloy construction does not crack or stain.
- The carriage and the center plate are quickly removable without tools.

Specifications

Operation:

Gravity feed.

Construction:

Smart 250, die-cast aluminum / Mirra 300 C anodized cast aluminum.

Knife:

One piece, chromium plated 100Cr6 forged carbon steel blade.

Sharpener:

Built-in, removable two stone dual action.

Slice thickness:

Infinitely variable up to 1/2"

Motor:

0.25 Hp (185W), belt-driven, air-cooled.

Electrical:

120V AC, 60Hz, 1.55 Amp.

Plug & Cord:

Attached, flexible, 3 wire SJT AWG 16, 6'4" long.

Switch:

ON/OFF Lighted Rocker Switch.



Certified to UL Standard 763 and NSF Standard 08
 Certified to CSA Standard C22.2

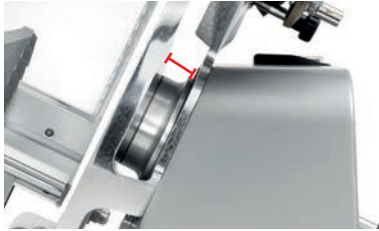

Wide gap between blade and body



Controls, Smart 250



Easy and fast breakdown for cleaning



Mirra 300 C

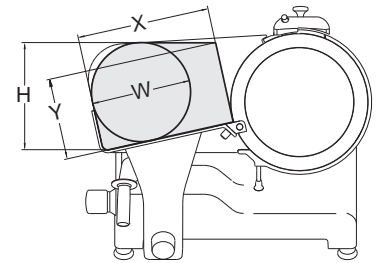
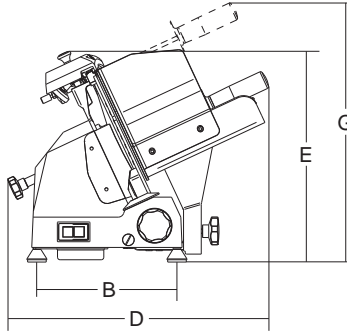
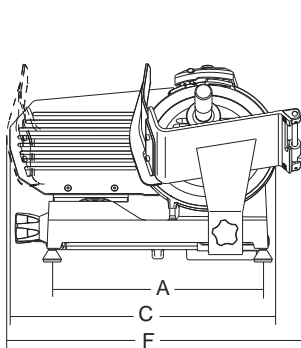

	Ø Blade	Motor	Out thickness	Blade rpm	Carriage stroke	Hopper	A	B	C	D	E	F	G	X	Y	H	W	Net weight	Shipping	Gross weight
	mm/inch	watt/Hp	inch.	rpm	inch.	inch.	inch.	inch.	inch.	inch.	inch.	inch.	inch.	inch.	inch.	inch.	inch.	lbs.	inch.	lbs.
Smart 250	250/10"	185-0,25	1/2"	335	9 5/8"	9 1/16" x 9 1/16"	15 9/16"	9 5/8"	19 11/16"	22 1/16"	14 9/16"	22 7/16"	18 11/16"	8 7/16"	5 11/16"	7 1/16"	6 11/16"	35	23 5/8" x 19 11/16" x 16 9/16"	40
Mirra 300 C	300/12"	185-0,25	1/2"	335	9 5/8"	9 1/16" x 9 1/16"	15 9/16"	9 5/8"	19 11/16"	22 1/16"	14 9/16"	22 7/16"	18 11/16"	8 7/16"	5 11/16"	8 7/8"	7 1/2"	35	23 5/8" x 19 11/16" x 16 9/16"	40