

ITEM #



ELECTRIC Series

Electric Stackable Oven

ELST37-36/2

Designed and manufactured with efficiency, durability, and modularity in mind, the stackable electric ovens achieve high-volume cooking and baking production through vertically integrated modular oven decks to reduce kitchen footprint. These electric deck ovens are available in 4 configurations, and are able to be vertically stacked up to four-decks in height. With temperatures ranging between 250° and 950°F, these versatile ovens are ideal for high-volume pizza making as well as Artisan baking and traditional cooking. The ovens can be configured as multi-deck ovens using a common chassis, or independently stacked as needed based upon production demand.

These ovens feature a large illuminated cooking area designed to maximize baking capacity. A manually controlled vent on each deck allows for humidity evacuation from the oven cavity as needed by application. Large full-width windowed doors are balanced by both counterweight and dual heavy-duty coil springs for durability, high-volume use and cooking capacity. Featuring the digital control touchscreen, each oven cavity operates using high-efficiency radiant heating technology located within brick deck plates maximizing thermal control independently for best baking results.



Standard Features

- 304-gauge stainless steel exterior front and doors. Galvanneal interior and sides.
- Full width front hinged door features a large recessed tempered glass window for high visibility of internal cooking chamber.
- Large insulated full-length safety door handle to prevent injury when opening and closing the door.
- Independently controlled upper and lower radiant heating allows precision temperature control and finished quality of food.
- Oven decks feature independent touch screen controls, allowing different operating temperatures within the stacked configuration.
- Proprietary MarraStone® refractory brick deck is 1½" thick and highly porous, designed to maintain temperatures greater than 1000°F for consistent high-volume production.
- Cooking cavity is designed to accept side by side 18"x 26" full-size sheet and baking pans.
- Ovens are controlled individually with MarraSmart® digital touch screen control technology, which is programmable and provides complete control of oven cooking conditions.
- 250° – 950°F cooking temperature range.
- Standard with interior lighting and manually controlled damper vent allows operator to evacuate humidity from the cooking chamber.
- 7" interior cook deck height
- Oven decks require individual dedicated electrical connections.
- Manufactured in the U.S.A
- 2-Year Deck warranty, 1-year parts and labor on electrical components.
- Approved for use with direct ventilation.

Cooking Capacity (Per Deck)

- 8" Pizzas: 16
- 10" Pizzas: 14
- 12" Pizzas: 9
- 16" Pizzas: 4

Total Cooking Surface: 9.3 Square Feet (Per Deck)
(cooking deck 36.8" x 36.4")

Production capacity varies depending upon type of food product being cooked, set temperatures and preparation methods used.

Configuration Options (Check all that apply)

Accessory Items

- Dough Tray
- Dough Tray Lids
- Dough Tray Dolley
- Deluxe Peel Tool Kit
- Standard Peel Tool Kit
- Wall Mounted Tool Rack

Options

- Direct Ventilation (Quoted Separately)
- Exhaust Fan
- Integrated Fan Interlock
- Variable Speed Fan Control
- Additional Modular Cooking Deck (Requires additional dedicated electrical connection)
- Top Mounted Stainless Steel Ventilation Cap
- Mobile Steel Stand (includes 5" locking casters)



ANSI Z83.11 CSA 1.8



ELECTRIC Series

ELST37-36/2

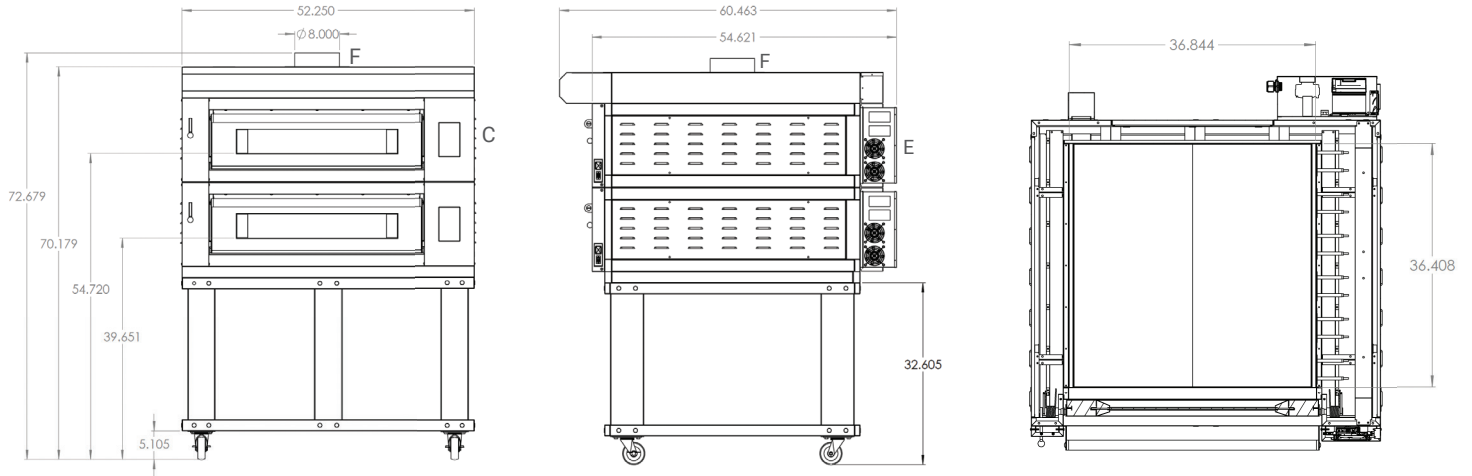

- C** - Controls
- E** - Electrical Connection Flexible Cord
- F** - Flue Collar

Venting Requirements

- The oven is vented through an 8" round duct collar. Ovens can be installed with a UL listed exhaust hood system or approved direct vent exhaust duct vented outside. Must be installed with a power exhausted vent.
- Optional variable speed fan controller and integrated fan interlock are available.
- Cubic Feet per Minute: 130 CFM (per cooking deck)
- Static Pressure: 0.01" W.C.
- Ventilation is subject to local jurisdictional approval

Dimensions Model ELST37-36/2

- Exterior (H x W x D): 72.67" x 52.25" x 60.46"
- Shipping (H x W x D): 80.00" x 72.00" x 72.00"
- Weight: 1,115 Crated Weight: 2,150
- Freight Class: 77.5 Shipped LTL

Clearance Requirements

- 2" minimum clearance on all sides from combustible surfaces
- 0" required from non-combustibles

Electrical Connection Requirements (Per Deck)

Region	Voltage	Hz	Amp	kW	Phase	Supply	Power Supply
North America	208V	50/60	40	14.6	3	4-wire	Rear, right side

Each oven cavity requires a separate dedicated electrical connection.

Due to ongoing product development and continuous improvement measures, specifications are subject to change without notice. All ovens are designed for commercial applications. All Marra Forni ovens are approved with a door which serves as a fire suppressor by completely sealing the oven cavity.

