



ITEM #: _____ QTY: _____
 MODEL #: _____
 PROJECT NAME: _____

030520

3601 S. Banker St. Effingham, IL 62401 • P.O. BOX 609 • Ph: (888) 431-2667 • Fax: (800) 433-2667

"WAL-C" BLENDED WALNUT CLASSIC COUNTRY WORK TABLE

FEATURES:

- AMERICAN BLACK WALNUT EDGE GRAIN BLENDED TOP, STANDARD BOOS BLOCK CREAM FINISH WITH BEESWAX
- PAINTED SLATTED SHELF
- SEE BASE COLOR SPEC SHEET FOR COLOR OPTIONS
- OPTIONS: UTENSIL DRAWER: CU-D14-P (NOTE: TWO DRAWERS AVAILABLE ON 60" LENGTH ONLY), 2-1/2" COMMERCIAL GRADE LOCKING CASTERS: CAS03, BASKET: DWB8156



WAL-C4824-S

OPTIONAL ACCESSORIES:



DWB8156



CAS03

"WAL-C" BLENDED WALNUT CLASSIC COUNTRY WORK TABLE

NO SHELF	QTY	1 SHELF	QTY	2 SHELVES	QTY
WAL-C3625		WAL-C3625-S		WAL-C3625-2S	
WAL-C4825		WAL-C4825-S		WAL-C4825-2S	
WAL-C6025		WAL-C6025-S		WAL-C6025-2S	
WAL-C4830		WAL-C4830-S		WAL-C4830-2S	
WAL-C6030		WAL-C6030-S		WAL-C6030-2S	
WAL-C4836		WAL-C4836-S		WAL-C4836-2S	
WAL-C6036		WAL-C6036-S		WAL-C6036-2S	

DETAILED SPECIFICATIONS

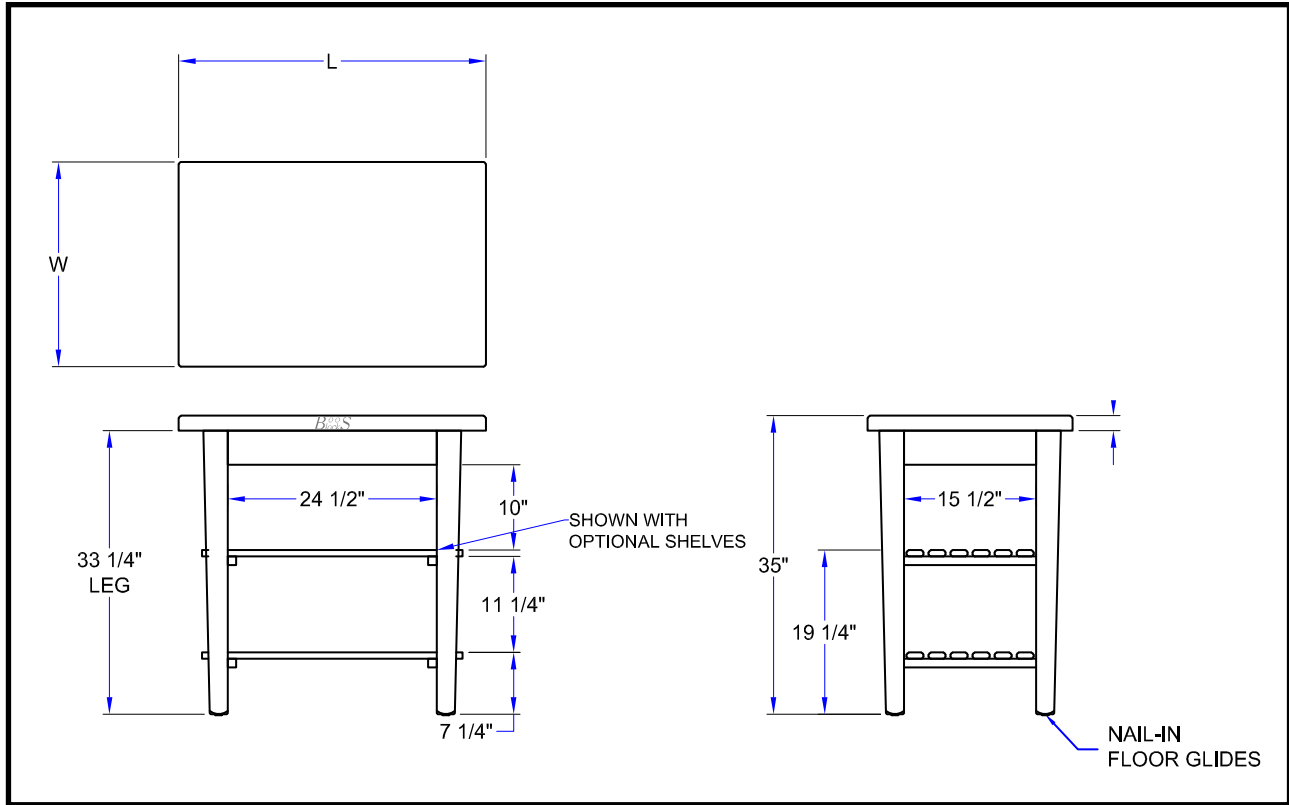

"WAL-C" BLENDED WALNUT CLASSIC COUNTRY WORK TABLE

L X W	NO SHELF	WT. (LBS)	1 SHELF	WT. (LBS)	2 SHELVES	WT. (LBS)
36" X 24"	WAL-C3625	58	WAL-C3625-S	78	WAL-C3625-2S	100
48" X 24"	WAL-C4825	77	WAL-C4825-S	97	WAL-C4825-2S	122
60" X 24"	WAL-C6025	86	WAL-C6025-S	114	WAL-C6025-2S	140
48" X 30"	WAL-C4830	84	WAL-C4830-S	111	WAL-C4830-2S	151
60" X 30"	WAL-C6030	101	WAL-C6030-S	133	WAL-C6030-2S	160
48" X 36"	WAL-C4836	103	WAL-C4836-S	143	WAL-C4836-2S	162
60" X 36"	WAL-C6036	121	WAL-C6036-S	153	WAL-C6036-2S	195

SOME UNITS SHIP UNASSEMBLED FOR REDUCED SHIPPING COST. ALL DIMENSIONS ARE TYPICAL. TOLERANCE +/- .500"
 John Boos & Co. is constantly engaged in a program of improving products and therefore reserves the right to change specifications without prior notice.



3601 S. Banker St. • Effingham, IL 62401 • PO BOX 609 • quotes@johnboos.com

www.johnboos.com

030520

231