



FD-1002MRJZ-C

Modular Ice Machine
Slim-Line Dispenser Series

FD-1002MRJZ-C
02/17/22
Item # 13620

W x D x H
22" x 24" x 26"

Shipping Dimensions
28^{1/2}" x 26^{3/4}" x 32"

FD-1002MRJZ-C
Remote Air-Cooled Cubelet
Shown on Lancer
IBD Bold 30i



Item #: _____
Project: _____
Qty: _____
AIA#: _____

Features

- ▶ Durable stainless steel exterior
- ▶ Advanced CleanCycle24™ design 
- ▶ Stainless steel auger with greaseless bearing

- Up to 821 lbs. of ice production per 24 hours
- 2 second flush cycle every hour
- Flush cycle removes sediment for cleaner ice
- Infrared bin control for easy cleaning and reliability
- Protected by H-GUARD Plus  Antimicrobial Agent
- Ice on beverage design
- Popular cubelet ice
- R-404A Refrigerant

Available on Bins:

B-250SF B-500SF B-700SF B-800SF B-900SF

Top kit may be required; See Bin Spec Sheets.

Warranty:

3 Year Parts & Labor on entire machine. 5 Year Parts on Compressor; air-cooled condenser coil. Valid in United States, Canada, Puerto Rico and U.S. Territories. Contact factory for warranty in other countries.

Condenser	Model	ICE PRODUCTION		WATER USAGE			ELECTRICAL						
		Air / Water Temp Lbs. per 24 hours 70°/ 50°F	90°/ 70°F	Potable Gal. per 100 lbs. 90°/ 70°F	Condenser Gal. per 100 lbs. 90°/ 70°F	kWh Used per 100 lbs. 90°/ 70°F	Max. Fuse Size or HACR Circuit Breaker	Amperage	Voltage	Circuit Wires (including ground)	Heat Rejection BTU/hr.	Refrigerant Charge Amount	Net / Ship Weight (lbs.)
Remote	FD-1002MRJZ-C	821	680	12.0	N/A	4.94	20A	15.23A	115V/60/1	3	8,500	2 lb. 3.3 oz. 4 lbs. 1 oz. †	176 / 210

†(with condenser)

Cube Dimensions*

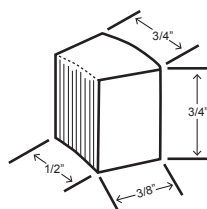

* approximate size in inches, image not to scale

Operating Limits

- Ambient Temp Range 45 - 100°F
- Water Temp Range 45 - 90°F
- Water Pressure 10 - 113 PSIG
- Voltage Range 104-127V

Service

- Panels easily removed and all components accessible for service.
- Allow 24" (61 cm) clearance at top for removal of auger and 6" (15 cm) clearance at rear and sides for proper air circulation and ease of maintenance/service.

Plumbing

- Icemaker Water Supply Line: Minimum 1/4" Nominal ID Copper Water Tubing or Equivalent
- Icemaker Drain Line: Minimum 3/4" Nominal ID Hard Pipe or Equivalent

Water Filter

Please refer to water filter specification sheet for recommendations.

Hoshizaki reserves the right to change specifications without notice.



FD-1002MRJZ-C

Modular Ice Machine
Slim-Line Dispenser Series

FD-1002MRJZ-C
02/17/22
Item # 13620

FRONT VIEW

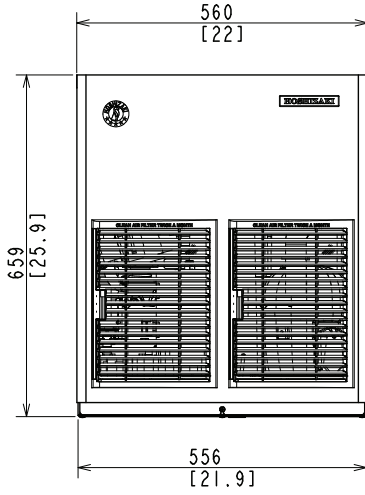

SIDE VIEW

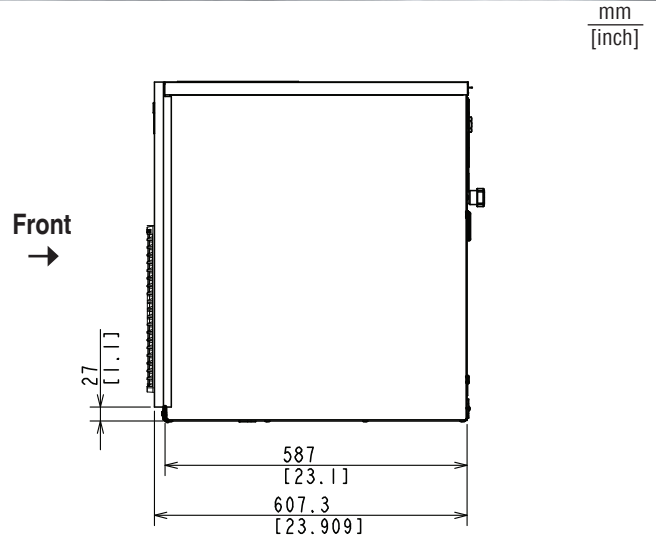

REAR VIEW

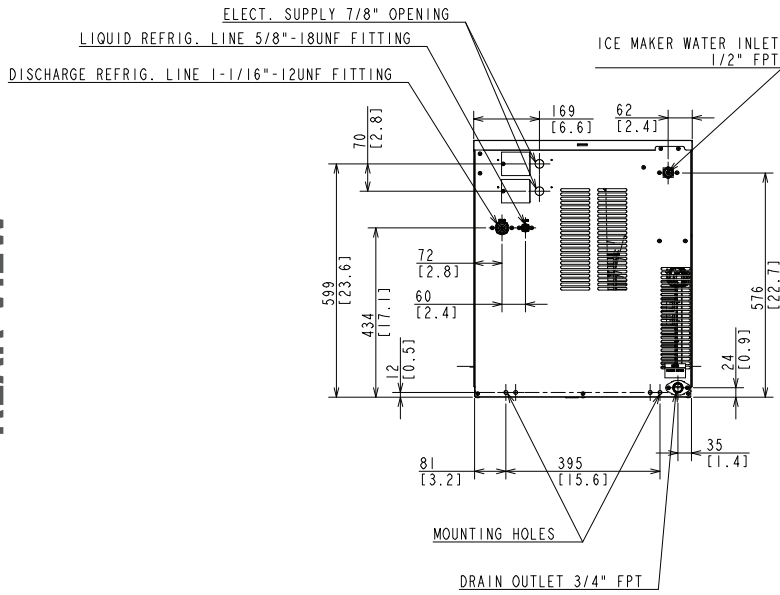

BOTTOM VIEW

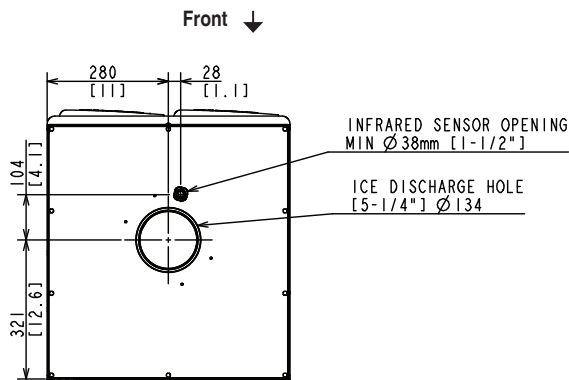

URC-5FZ Remote Condenser (Sold Separately)
(W x D x H) 21^{13/16} x 14^{1/16} x 32^{13/16}
For Use with FD-1002MRJZ-C

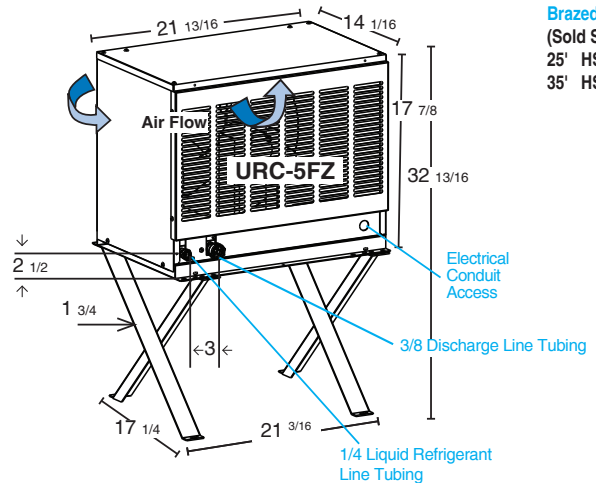

Brazed Line Sets (Sold Separately)
25' HS-5587
35' HS-5588

Voltage supply for ice maker and condensing unit are separate.