



Operation Manual  
For  
**Sodir**  
SEF-80 Salamander



765 Westminster Street • Providence, Rhode Island 02903 • U.S.A.  
Tel: (401) 273-3300 Fax: (401) 273-3328  
[www.equipex.com](http://www.equipex.com) e-mail: [service@equipex.com](mailto:service@equipex.com)





## IMPORTANT SAFEGUARDS

When using electrical appliances, basic safety precautions should always be followed, including the following:

1. Read all the instructions before use.
2. Do not touch hot surfaces; use handles or knobs.
3. To avoid electric shock, **do not immerse the power cord, or any part of the unit**, in any liquid.
4. Close supervision is necessary when any appliance is used, especially around children.
5. Unplug appliance from the electrical outlet when not in use, and before cleaning. Allow appliance to cool before installing or removing any parts or accessories, and before cleaning.
6. Do not operate any appliance with a damaged cord or plug, or if appliance should sustain damage, or malfunction in any way. In this event, return appliance to the nearest authorized service facility for examination, repair or adjustment.
7. The use of accessories and/or attachments not recommended by the appliance manufacturer may cause injury or damage to the appliance, and may void your warranty.
8. Do not use outdoors.
9. Do not allow the power cord to hang over the edge of a table or counter, or to be exposed to hot surfaces, as damage may occur.
10. Do not place appliance on or near a burner, or in a heated oven.
11. To disconnect an appliance, **first** turn all controls to the 'off' position; *then* unplug the power cord from the wall outlet.
12. Do not use appliance other than for its intended use.
13. SAVE THESE INSTRUCTIONS FOR LATER USE!

## INTRODUCTION

The **SODIR** Model SEF-80 finishing oven is designed to offer quality finishing and broiling. The unit is constructed of food service quality stainless steel and utilizes two groups of four infrared quartz heating elements each (total of 8 elements) located in the top of the finishing oven. The finishing oven features a pullout bottom pan with a removable wire rack and an adjustable heating wire shelf. The unit is equipped with two 4-position rotary switches each offering a choice of operating either all four heating elements, or two outside elements, or two inside elements, as well as with two red power indicator lights. The Model SEF-80 is a countertop unit furnished with 4" legs, however, it is also available as a wall-mounted unit.

### *Specifications*

<b>Model</b>	<b>Electrical</b>	<b>Plug Configuration</b>
SEF-80	208/240V, 3PH, 5KW, 13/15A	Cord only

## INSTALLATION

The **SODIR** Model SEF-80 finishing oven needs to be connected to a grounded outlet of proper voltage (208/240V, 3PH). **DO NOT** place the unit in a damp area or near steam source. Make sure that the side and rear ventilation panels are not blocked. Maintain 6" clearance at each side, and at least 4" clearance at rear. **Not to be installed over or near high heat or open flame without an insulated shelf - consult factory.**

## ASSEMBLY

The unit comes from the factory completely assembled. However, prior to using the finishing oven, the heating wire shelf, the pull-out pan and the rack should be cleaned with a damp cloth or sponge and a mild soap and water mixture. Use a clean lint-free cloth to remove the excess water or soap.

### *Wall Mounting*

In order to wall mount the Model SEF-80 finishing oven, use a specially designed SM-1 mounting kit. Attach the mounting plate to the wall. You will need six (6) screws to do that.

**Note:** Make sure that the wall is able to hold a minimum of 130 lb.

After the mounting plate is securely attached to the wall, lift the unit and align the slots on the back panel with the hooks on the mounting plate. Hang the unit on the hooks.

### ***Bottom Pan Removal***

The bottom pan is mounted on two slides. Two stop pins located under the pan prevent it from accidental dropping out. To remove the pan, first remove the rack and slide the pan outward. When the shelf hits the stop, lift up the front center of the pan. Once it cleared the stop pins, the pan will slide off. Reverse the procedure for assembly.

## **OPERATION**

Place the food on the heating wire shelf. Select the position of the shelf and place it on to the holding brackets located on the frame of the unit. To operate the Model SEF-80 finishing oven, turn each rotary switch knob to one of the following positions (clockwise):

- ALL FOUR heating elements ON
- TWO OUTSIDE elements ON
- TWO INSIDE elements ON

Select the operating mode that will allow to achieve the desired cooking or finishing results. The red power indicator light(s) will be lit. The heating elements can produce heat up to 1900 F at the surface of the element. The distance between the heating elements and the product, as well as the number and position of the working elements will control the amount of heat over the product and, therefore, the speed and intensity of broiling or finishing.

The bottom pullout pan serves as a catch for drippings. To make clean up much easier, it might be a good idea to keep about ½” of water in the pan. The use of water helps to prevent drippings from scorching and creating smoke.

**WARNING: Do not put uncovered hands under or near the elements while the unit is on. Use approved fireproof gloves or mittens to remove food from under the elements.**

**CAUTION: The surface of the oven's top and the heating wire shelf are hot while the unit is in operation**

**DO NOT** leave cooking food unattended  
**DO NOT** leave the unit on while not in use

To turn the unit off, put each rotary switch knob in to the OFF position. The red power indicator lights will then go out. Remove the heating shelf or simply remove the product from the shelf and leave the finishing oven to cool.

## CLEANING

**WARNING: Disconnect (unplug) electrical power supply before cleaning**

**CAUTION: Do not spray hot heating elements with any liquid**

Cleaning is very important in maintaining the **SODIR** finishing oven in good working order. Allow the unit to cool before cleaning. Remove the heating shelf and the wire rack and clean them separately. If necessary, remove the pullout bottom pan following the procedure described in the **ASSEMBLY** section of the manual. The heating shelf, the wire rack and the bottom pan are dishwasher safe and, therefore, can be washed in a dishwasher or in a pot sink. Use a cloth dampened in a soap and water mixture to clean the exterior and interior stainless steel surfaces. Use a clean, lint-free cloth to remove the excess water or soap.

- DO NOT** immerse the unit in water or any other liquid
- DO NOT** spray the housing with any liquid
- DO NOT** wash the unit under running water
- DO NOT** allow water to drip into the housing around the electrical components

Inspect all parts on a regular basis to ensure that all parts are in good working order. If a part is damaged, have the unit repaired by an authorized service agency prior to returning the unit to operation. If you have trouble locating a service agency in your area, call **EQUIPEX, LTD.** at 1-800-649-7885 and ask for customer service.

# SODIR FINISHING OVENS

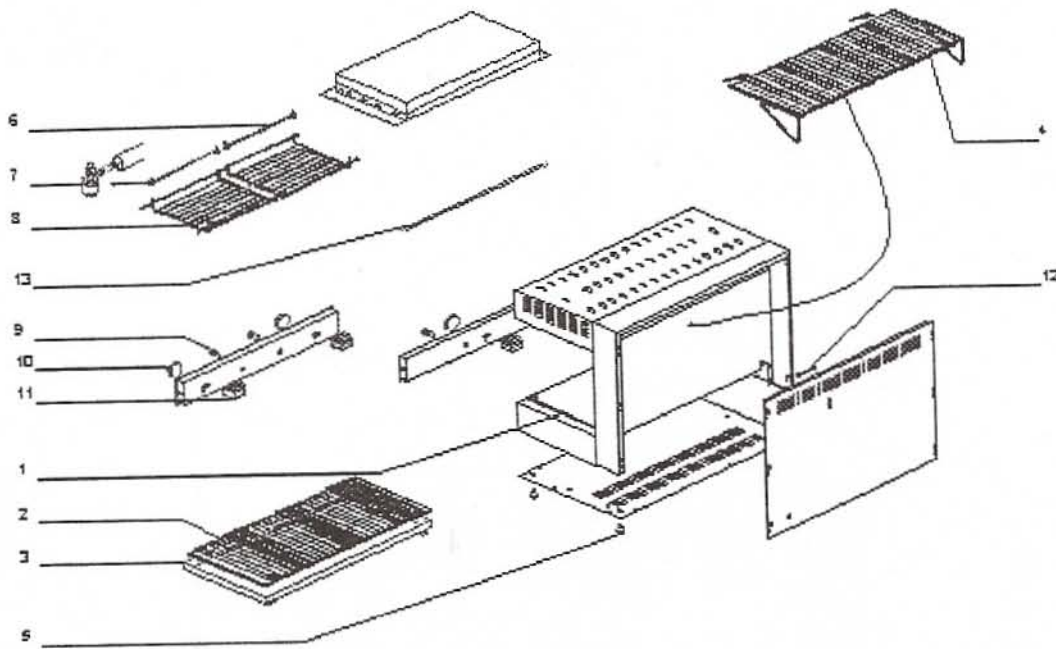

**MODEL SEF-80**

EQUIPEX, LTD.			25-Aug-00	SPFINO-80E-02
765 Westminster Street, Providence, RI 02903				
tel: (401) 273-3300 fax: (401) 273-3328			Toll free: 1-800-649-7885	
SODIR Model SEF-80 Finishing Oven (208-240V/60/3 Phase)				
Drawing #	Part Number	Quantity	Description	Old Part Number
1	F02001	2	Tray Guide	P-S602001
2	F01004	1	Tray Wire Grid	P-S601004
3	72006I210	1	Tray	P-S740110
4	F01005	1	Cooking Wire Shelf	P-S601005
5	A17004	4	Foot	P-S113005
6A	D04006	8	Quartz Tubes	P-S404006
6B	D01031	8	Heating Element, 220V	P-S401031
7	A09003	16	Steatite/Insulator	P-S109003
8	F01003	2	Tube Protecting Grid	P-S601003
9	A08008	2	Red Pilot Light, 220V	P-S108005
10	A17078	2	Knob, Thermostat	P-S114078
11	A01001	2	Control Switch	P-S101001
12	OEM0022	1	Power Cord, 220V (no plug)	301006



## LIMITED WARRANTY

Your new **EQUIPEX** product is warranted to the original purchaser for a period of one year from the date of purchase.

This limited warranty is against defects from original factory imperfections in material and/or workmanship and includes labor for replacement of defective parts, provided repairs are performed by an authorized service agency. Our obligation under this warranty is limited to repairing or replacing any part or parts thereof. The CUSTOMER must inform the Service Agency of warranty coverage and provide a copy of the dated sales or delivery receipt BEFORE WARRANTY REPAIRS BEGIN. Replacement parts and accessories are warranted for ninety (90) days from the date of purchase when purchased separately and will be verified by dated sales receipt or packing slip for that item. All parts or accessories replaced under warranty must be returned to the Service Agency.

This warranty applies only to equipment under normal use and service in the U.S.A. and Canada. It does not apply to any item which has been repaired or altered in any way so as, in the judgment of EQUIPEX, to affect its reliability.

### **THE FOLLOWING ARE NOT COVERED UNDER WARRANTY:**

1. Damage caused by abuse, misuse or dropping or other similar incidental damage caused by, or as a result of, customer failure to follow assembly, operation, cleaning, user maintenance or storage instructions.
2. Labor to replace inoperative parts such as bulbs, plugs or racks due to normal wear and tear or abuse.
3. Materials or labor to repair scratched, stained, chipped, pitted, dented or discolored surfaces, attachments or accessories.
4. Transportation charges to or from a service agency for repair of your machine. If you should have questions relating to this issue, please call **Equipex** at 1-800-649-7885.
5. Labor charges to install or test attachments or accessories, which are replaced for any reason.
6. SHIPPING DAMAGES. Visible and hidden damages are the responsibility of the freight carrier. The consignee must file the claim promptly against the carrier. KEEP ALL ORIGINAL CONTAINERS AND PACKAGING MATERIAL FOR CARRIER INSPECTION.
7. Products placed or stored in the equipment are not subject to this warranty and no responsibility is assumed thereof.

**THIS WARRANTY IS GIVEN EXPRESSLY AND IN LIEU OF ALL OTHER WARRANTIES, EXPRESSED OR IMPLIED, FOR MERCHANTABILITY AND FOR FITNESS TOWARD A PARTICULAR PURPOSE AND CONSTITUTES THE ONLY WARRANTY MADE BY EQUIPEX, LLC. IT NEITHER ASSUMES, NOR AUTHORIZES ANY PERSON TO ASSUME FOR US, ANY OTHER LIABILITY IN CONNECTION WITH THE SALE OF THE SUBJECT EQUIPMENT.**

For service, please call **EQUIPEX** at 1-800-649-7885, menu option # 3

765 Westminster Street • Providence, Rhode Island 02903 • U.S.A.

Tel: (401) 273-3300

Fax: (401) 273-3328

[www.equipex.com](http://www.equipex.com)

e-mail: [service@equipex.com](mailto:service@equipex.com)