



CNVX-14G

CNVX-14G

Single or Double Gas Convection Oven
Also designed to stack under
BCX-14G or BX-14G Combi Ovens

Refer to BCX-14G and BX-14G specification sheets for information on the combi ovens.



BCX-14G double shown with optional SmartTouch2 controls

Project _____

Item No. _____

Quantity _____

All data is shown per oven section, unless otherwise indicated.

Refer to operator manual specification chart for listed model names.

EXTERIOR CONSTRUCTION

- Stainless steel top, front, sides and back
- Dual pane tempered viewing window with hinged inner glass for easy cleaning
- Door mounted condensate trough
- Top and bottom mount, easily adjustable door hinges
- Pivot out user interface panel for service access

INTERIOR CONSTRUCTION

- Fully welded stainless steel frame
- Fully insulated cooking chamber
- Fixed drain bottom center of cavity
- Easily removable stainless steel side rails
- Coved corner liner for ease of cleaning

OPERATION

- Programmable manual control stores up to 100 recipes
- Core probe cook & hold capabilities with 4" removeable fillet core probe
- Hydroburst for shot of 100% humidity at any time during the cook cycle
- Multiple speed reversing fan for even bake
- Dual stage door latch
- Integral door switch
- Electronic spark ignition

CAPACITY

- Fourteen 12" x 20" x 2-1/2" deep pans at 3-1/4" spacing
- Seven 18" x 26" deep pans at 3-1/4" spacing

STANDARD FEATURES

- Seven (7) stainless steel wire shelves per section
- Hinged pressure panel for cleanability
- Halogen lights for superior cavity illumination
- Retractable hose reel (excluding top sections)
- Stacking kit and casters for double stack ovens
- Pressure spray bottle for oven cleaning
- 4" core temperature probe
- Floor stand with rack supports
- Start-up inspection service by factory authorized service agent
- One year parts and labor oven warranty*

* For all international markets, contact your local distributor.

OPTIONS AND ACCESSORIES

(AT ADDITIONAL CHARGE)

- **Legs & Casters**
 - 6" (152.4mm) adjustable legs
 - 6" (152.4mm) seismic legs
 - 25" (635mm) adjustable legs
 - Stand mount casters
- **Core Probes**
 - 4" duel sensing probe
 - 6" duel sensing probe
 - Additional 4" fillet probe
- SmartTouch2 control - NEW 7-inch touchscreen stores up to 500 recipes. Includes rack timing, multi-shelf recipes, easy download for recipe writing on your laptop, and HACCP storage capability
- Additional stainless steel wire shelves
- Backflow preventer
- Side heat shield
- Chicken roasting rack
- Extended warranty

OPTIONS AND ACCESSORIES

(AT NO CHARGE)

- LP gas
- 208/240 volt



Intertek



BLODGETT OVEN COMPANY

www.blodgett.com

42 Allen Martin Drive, Essex Junction, VT 05452
Phone: (802) 658-6600 • Fax: (802) 864-0183



CNVX-14G

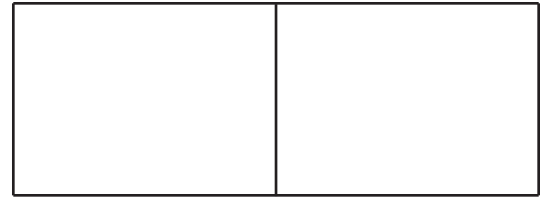

APPROVAL/STAMP

DIMENSIONS ARE INCHES (MM)

- ⊗ Electric ⊕ Gas ⊖ Drain
- ⊕ Unfiltered Water - Condensate, cold only
- ⊖ Filtered Water - Hydroburst, hot or cold

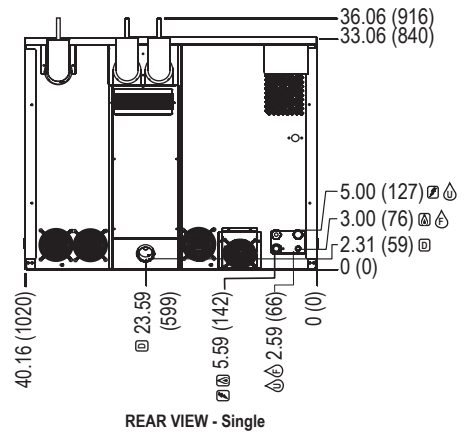
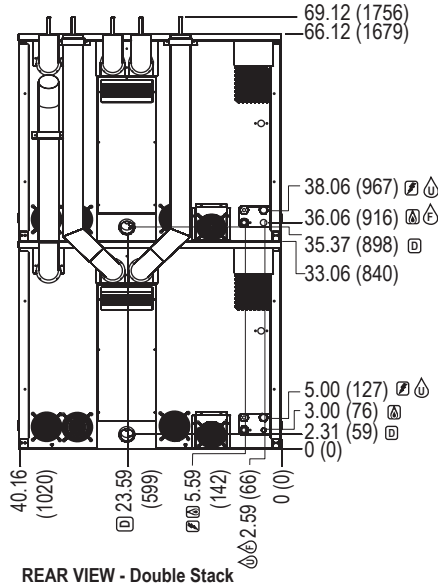
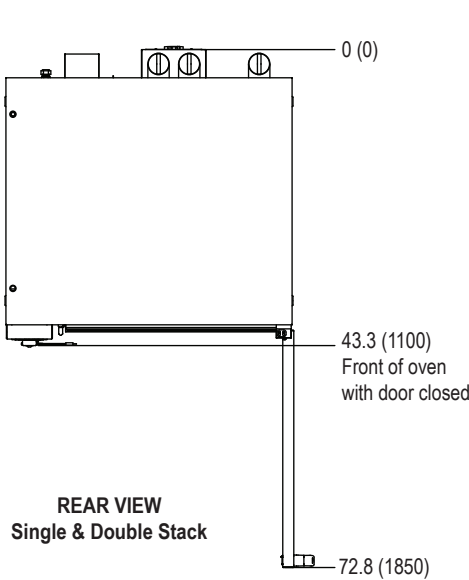

SHORT FORM SPECIFICATIONS: Provide Blodgett Combi model CNVX-14G single, gas convection oven. Unit shall have the ability to cook with hot air at an operating range 140F to 500F, and low temperature cooking and holding. Unit shall have programmable manual control capable of storing 100 recipes and USB connection. Oven capacity to accept 7ea 18x26 bake pans or 14ea 12x20x2.5" full size steam table pans with 3-1/4" spacing. Front access service user interface control panel and service diagnosis system. Unit shall be constructed with a fully welded stainless steel frame. Cooking chamber shall be constructed with 316 series with 2B dull stainless steel finish and coved corners. Retractable hose reel (excluding top sections) to include front water shut off valve. Unit shall include a four speed, bi-directional fan. Dual pane thermal glass window with 180 degree door swing, two-step safety door-latch with adjustable door hinges, door mounted drip. Unit to include a detachable 4" core temperature probe and halogen lights. Where applicable, quantities in this spec are doubled for stacked units. Unit can also stack with Blodgett model BCX-14G or BX-14G combination oven-steamers. A start-up inspection service will be performed by our factory-authorized agent at no cost to the operator. One-year parts and labor warranty, standard.

DIMENSIONS:

Floor space:	42.30" x 40.19" (1074 x 1021mm)
Unit Height:	
Single	33.06" (840mm)
Double	69.12" (1756mm) without casters/legs
Stacked with BCX-14G	69.22" (1758mm) without casters/legs
Stacked with BX-14G	69.12" (1756mm) without casters/legs
Additional Height:	
Low profile caster for stacked units	4" (101.6mm)
6" adjustable legs	6.88" - 8" (174.6-203.2mm)
6" adjustable seismic legs	6.63" - 8" (168.3-203.2mm)
25" adjustable legs	25.25" - 26.38" (641.4-670mm)
Stand w/rack supports	28" (711mm)

OVEN CLEARANCES:

Right Side	1" (25.4mm)
Left Side	6" (152.4mm)
Rear	6" (152.4mm)

MINIMUM ENTRY CLEARANCE:

Uncrated	33" (838mm) after adjustment of flue brackets
Crated	42" (1066.8mm)

POWER SUPPLY (per section):

Standard	115VAC, 12 amp, Nema 5-20R dedicated receptacle
Option	208-240VAC, 6 amp, Nema 6-15 dedicated receptacle
Export	Export voltages available on request
Blodgett recommends a Pass & Seymour, model 2097, GFCI due to the use of a variable frequency drive. Must be hard wired in some cases.	

NOTE: The company reserves the right to make substitutions of components without prior notice

GAS SUPPLY (per section):

3/4" NPT	
Inlet Pressure:	
Natural	7.0" W.C. static to unit
Propane	14.0" W.C. static to unit
Maximum Input:	
CNVX-14G & BX-14G	65,000 BTU/hr
BCX-14G	115,000 BTU/hr

WATER SUPPLY & DRAIN:

Good quality water feed is the responsibility of the owner. Water quality must be within the following general guidelines.

TDS: 40-125 ppm	Hardness: 35-100 ppm	pH: 7.0 - 8.5
Silica: <13 ppm	Chlorides: <25 ppm	Chlorine: <0.2 ppm
Chloramine: <0.2 ppm		

Water Supply: 3/4" hose cold water connection

Drain: 2" drain connection Maximum drain temperature 140°F (60°C)

The drain piping must consist of temperature resistant material, greater than 160°F, and be of adequate diameter not to cause flow restriction. Improper materials may deform and cause restrictions, thus affecting performance.

Appliance is to be installed with backflow protection in accordance with Federal, State or Local codes.

SHIPPING INFORMATION:

Approx. Weight:		
Single section	595 lbs. (270 kg)	*Use single section weight
Double stack*	1225 lbs. (556 kg)	when ordering to stack with
Stand w/guides	140 lbs. (64 kg)	BCX-14G or BX-14G

Crate sizes (per section):

44.5" H x 42" W x 54.25" D (1130 x 1067 x 1378mm)