



BEVERAGE-AIR

Project: _____	AIA#
Item: _____	
Location: _____	SIS#
Approved: _____	

DP46HC FOOD PREPARATION: DELI/PIZZA PREP SERIES

FOOD PREPARATION TABLES

DP46HC Deli/Pizza One Door Prep Table

Hydrocarbon Series

**MODEL:
DP46HC**



5 Year Parts/Labor Warranty Available
7 Year Compressor Warranty

CABINET CONSTRUCTION

- Stainless steel front, sides, top, door, and grille (galvanized back & bottom)
- Interior liner is made of corrosion resistant aluminum
- Aluminum top interior liner prevents spill from falling into cabinet
- Stainless steel top
- Removable hoods and insulated lid assemblies are made of matching stainless steel
- Self-closing door with 120° stay-open feature, on lift-off hinges
- Snap-in door gaskets
- Easy lift-off door removal for service and cleaning
- Field reversible door
- 3" Casters, 2 with brakes standard
- 19" Wide reversible cutting board constructed of white polyethylene plastic
- Cutting board removable for cleaning
- Two (2) epoxy-coated steel wire shelves
- Units will accept pans up to 6" deep (pans are not included)
- Compressor available on left or right, specify at time of unit order

OPTIONS & ACCESSORIES

- 3 Year parts/labor standard, additional 2 year warranty available
- Stainless steel back
- Stainless steel interior
- Clear lid
- Combination door/drawer models
- Overshelf kits
- Additional shelves
- Shelf clips
- Pan support
- Door lock
- Composite cutting board
- Thermometer
- Night cover
- Bun tray rack
- 6" Casters
- 6" Legs black or seismic/flanged
- Remote option* (see note on back page)

REFRIGERATION SYSTEM

- Uses environmentally friendly, energy efficient R290 refrigerant, and meets all regulatory requirements for CARB, SNAP, DOE & more
- Adaptive defrost
- Epoxy coated evaporator coil
- Enhanced airflow maintains temperatures between 36° - 38°F



Please verify qualifying units by visiting:
www.energystar.gov/cfs

3779 Champion Blvd., Winston-Salem, NC 27105
1-888-845-9800 Fax: 1-336-245-6453
Beverage-Air.com Sales@bevair.com



BEVERAGE-AIR

MODEL	DP46HC
EXTERNAL DIMENSIONAL DATA	
Width Overall	46"
Depth Overall with Cutting Board	36 ⁷ / ₈ "
Height Overall with Casters & Lid Open	53 ¹ / ₈ "
No. of Doors	1
Depth with Door Open 90°	55 ¹ / ₄ "
Door Opening	21 ⁵ / ₈ " x 23 ¹ / ₂ "
Depth, Cutting Board	19"
INTERNAL DIMENSIONAL DATA	
NET Capacity (cubic ft.)	12.0
Internal Width Overall (in)	42"
Internal Width Usable (in)	21 ⁷ / ₈ "
Internal Depth Overall (in)	26"
Internal Height Overall (in)	23 ⁷ / ₈ "
No. of Shelves	2
ELECTRICAL DATA	
Full Load Amperes	4.5
REFRIGERATION DATA	
Horsepower	1/2
Capacity (BTU/Hr)	2940
Heat Rejection (BTU/Hr)	4410
Charge (lbs/grams/ounces)	0.231 / 105 / 3.7
SHIPPING DATA	
Gross Weight - Crated	336 lbs
Height - Crated	49"
Width - Crated	49"
Depth - Crated	37"

*NOTE: Remote units are field wired and come with 6" legs. Refrigerant must be specified at time of order.

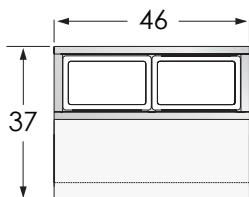

Top Configuration

Deli/Pizza Preparation Table Model: DP46HC

Model Views

Required Clearance: 2" Bottom & 2" Rear

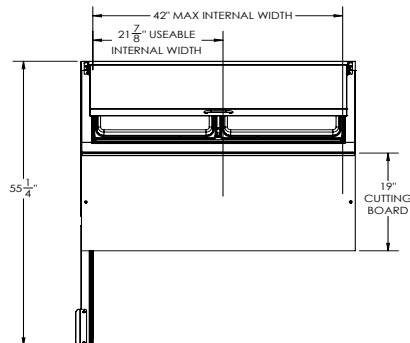

PLAN VIEW

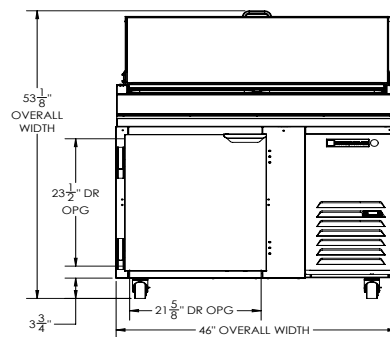

ELEVATION VIEW

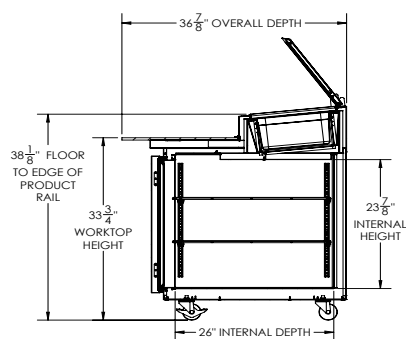

SIDE VIEW

ELECTRICAL CONNECTION



115/60/1
NEMA 5-15P

Unit pre-wired at factory and include 8' long cord and plug set.



3779 Champion Blvd., Winston-Salem, NC 27105 1-888-845-9800 Fax: 1-336-245-6453 Beverage-Air.com Sales@bevoir.com

an Ali Group Company



The Spirit of Excellence