



**John
BOOS**
Since 1887

ITEM #: _____ QTY: _____

MODEL #: _____

PROJECT NAME: _____

051019

3601 S. Banker St. Effingham, IL 62401 • P.O. BOX 609 • Ph: (888) 431-2667 • Fax: (800) 433-2667

"MHS" MOBILE HAND WASH STATION

FEATURES:

- 16 GAUGE STAINLESS STEEL TOP
- 18 GAUGE STAINLESS STEEL PANELS
- 20 GAUGE STAINLESS STEEL HINGED DOOR W/MAGNETIC CATCHES
- MARINE INVERTED "V" FRONT EDGE
- 16 GAUGE 8" REAR RISERS & SIDE SPLASHES
- DROP-IN SINK (BOWL SIZE: 10" X 14" X 5")
- DECK MOUNT FAUCET 4" O.C. WITH GOOSE NECK SPOUT
- SOAP AND PAPER TOWEL DISPENSER
- HEAVY DUTY 5" LOCKING CASTERS
- SHURFLO FRESH WATER PUMP
- ARISTON GL2.5 WATER HEATER
- CPS 5 GAL CLEAN WATER CONTAINER
- CPS 6 GAL GREY WATER CONTAINER
- GFI OUTLET WITH 6' CORD
- ALL COMPONENTS ARE UL LISTED



CONSTRUCTION:

- TIG WELDED, EXPOSED WELDS ARE POLISHED TO MATCH ADJACENT SURFACE.

MATERIAL:

- TOP: 16 GAUGE STAINLESS STEEL TYPE 300 STAINLESS STEEL WITH # 4 POLISH, SATIN FINISH
- PANELS: 18 GAUGE STAINLESS STEEL
- SHELF: 18 GAUGE STAINLESS STEEL
- DOOR: 20 GAUGE



MOBILE HAND WASH STATION

MODEL	QTY
MHS-2624	

DETAILED SPECIFICATIONS

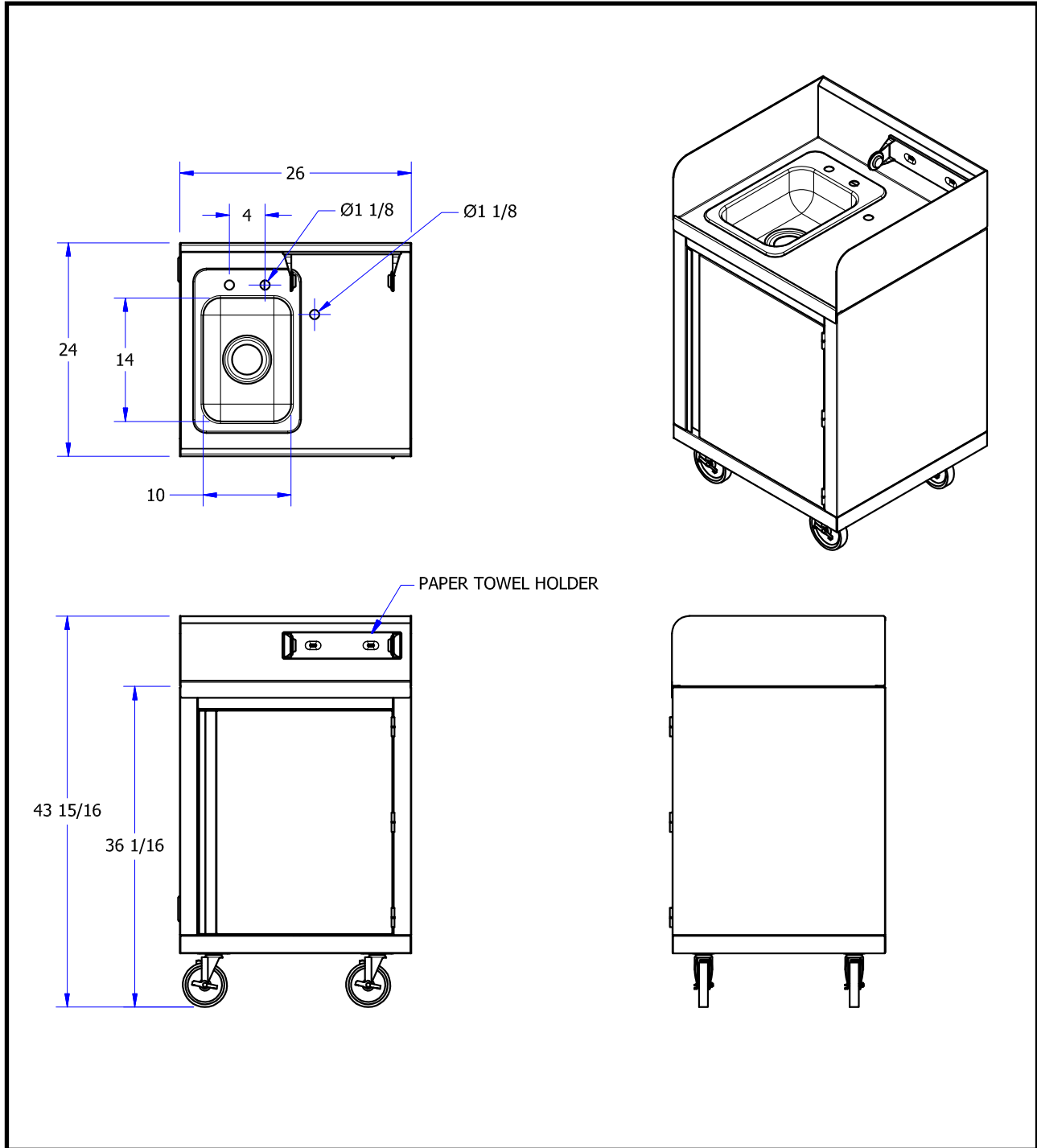

MOBILE HAND WASH STATION

MODEL	OVERALL SIZE (LxWxH)	SINK SIZE (LxWxH)	WT. (LBS)
MHS-2624	26" X 24" X 36"	10" X 14" X 5"	285

SOME UNITS SHIP UNASSEMBLED FOR REDUCED SHIPPING COST. ALL DIMENSIONS ARE TYPICAL. TOLERANCE +/- .500"
 John Boos & Co. is constantly engaged in a program of improving products and therefore reserves the right to change specifications without prior notice.



Boos
locks

AQ AutoQuotes

3601 S. Banker St. • Effingham, IL 62401 • PO BOX 609 • quotes@johnboos.com

www.johnboos.com

051019

695