



RADIANT BROILER WITH OVERHEAD WARMING OVEN AND SECTIONAL BASE

Job # _____

Platinum Series

Standard Features

- 110,000 BTU NAT (90,000 BTU LP) two broiler burners with separate controls
- Stainless steel front, sides and back
- Removable drip drawer
- Rugged grid height adjustment mechanism with four positions
- Warming oven -heated by broiler flue gases (25" wide x 25" deep)
- Fully insulated lining and burner boxes
- Broiler grid is 24-1/2" wide and 28" deep -easily rolls out 17-1/4"
- 6" adjustable legs
- 1-1/4" front manifold and rear gas connection standard
- (1) year limited parts and labor warranty (reference <http://www.southbendnc.com/service.html> for limited warranty details)

Standard Features of Oven Bases

- 45,000 BTU NAT (45,000 BTU LP) oven with electronic pilot ignition
- Cool-to-the-touch handle
- Porcelain enamel interior
- 2 oven racks with Standard and 3 racks with Convection
- "Insta-On" thermostat ranging from 175°F to 550°F
- Standard oven interior is large enough to fit 26" x 26" sheet pan either way
- Convection oven models have 1/2hp, two speed blower
- NEMA 4 water resistant controls

Standard Features of Cabinet-Base Models

- Stainless steel cabinets with dual side by side removable doors

Warming Oven

- Model P32 has a warming oven that is heated by broiler flue gases (25" wide x 25" deep).

P32C-32B (Cabinet Base)
 P32D-3240 (Standard Oven Base)
 P32A-3240 (Convection Oven Base)



(Model P32D-32B)

STANDARD CONSTRUCTION SPECIFICATIONS

Exterior Finish: Top, front, sides and back are 430 stainless steel #3 polish.

Broiler: Radiant broiler with overhead warming oven. Two radiant broiler burners with separate controls - total BTU: 110,000 NAT (90,000 BTU LP). Fully insulated lining and burner box. Roll-out broiler grid is 24-1/2" wide and 28" deep (rolls out to 17-1/4"), with four height positions.

Battery: Position in battery -left, right or on end. If the item is at the end of a battery, the end side will be solid (rather than have a coverplate over the end of the front manifold).

Legs: Stainless steel 6" adjustable legs standard.

Warming Oven: 25" wide and 25" deep oven, located on top of broiler, is heated by the broiler flue gases.

Model 32D: 45,000 BTU NAT (45,000 BTU LP) with electronic ignition and thermostat range of 175°F to 550°F. Porcelain enamel interior, measuring 14" high x 26" wide x 26-1/2" deep. Two racks with 5-position side rails.

Model 32A: 45,000 BTU NAT (45,000 BTU LP) convection oven with electronic ignition and thermostat range of 175°F to 550°F. Porcelain enamel interior, measuring 14" high x 26" wide x 24" deep. Three racks with 5-position side rails. Two-speed, 1/2 hp blower motor.

Model 32C: Stainless steel cabinet base with removable doors that open from the center.



Models: P32N-32B P32C-32B P32D-3240 P32A-3240

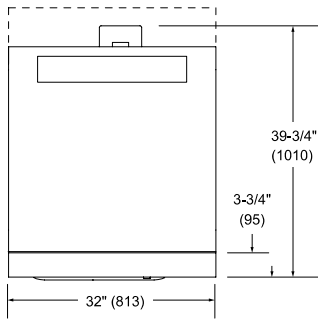

SHIPPING CRATE DIMENSIONS & WEIGHT					
MODEL	WIDTH	HEIGHT	DEPTH	VOLUME	WEIGHT
P32C-32B	45.5" (1156)	83" (2108)	55" (1397)	120.2 cu ft (3.40 cu m)	355 lbs (161.0 kg)
P32D-3240	45.5" (1156)	83" (2108)	55" (1397)	120.2 cu ft (3.40 cu m)	916 lbs (415.5 kg)
P32A-3240	45.5" (1156)	83" (2108)	55" (1397)	120.2 cu ft (3.40 cu m)	955 lbs (433.2 kg)

Dimensions shown in inches and (millimeters)

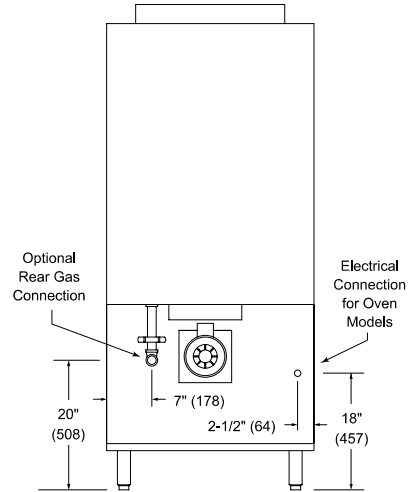
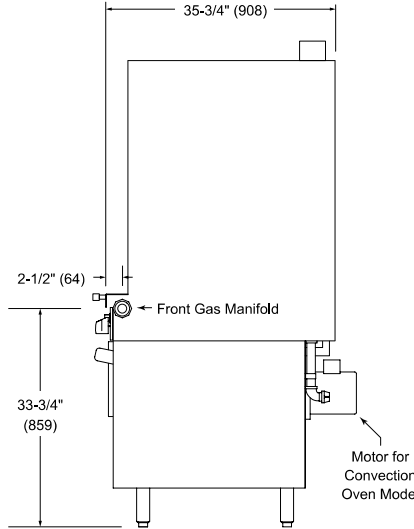
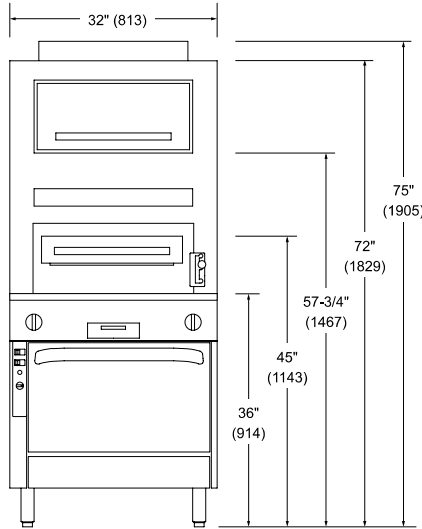

UTILITY INFORMATION

GAS: Each unit has a 1 1/4" front gas manifold that couples to the adjacent sectional unit(s), and a 1" rear gas connection with a male NPT connector. Minimum supply pressure is 7" W.C. for natural gas and 11" W.C. for propane. All sectional units require a regulated gas supply; pressure regulator to be ordered separately. If using a flexible hose gas connection, the I.D. of the hose must not be smaller than the connector on the unit and must comply with ANSI Z21.69, providing an adequate means of restraint to prevent undue strain on the gas connection.

MODEL	GAS (BTU/Hr)		ELECTRICITY (AMPS)	
	NATURAL	PROPANE	120V	208/240V
P32C-32B	110,000	90,000	-	-
P32D-3240	155,000	135,000	1.0	1.0
P32A-3240	155,000	135,000	4.8	2.6

ELECTRICITY: Both standard and convection oven models require 50Hz or 60Hz single phase. 120V models have a 7ft. power cord with ground plug. 208/240V models have a terminal block for connection to a single phase 208/240V source.

MISCELLANEOUS

- If casters are used with flex hose, a restraining device should be used to eliminate undue strain on the flex hose.
- Minimum clearance from noncombustible construction is zero (blower of convection oven model requires 2" rear clearance). Minimum clearance from combustible construction is 6" on sides and 6" on rear.
- Install under vented hood.
- Check local codes for fire and sanitary regulations.

NOTICE: Southbend has a policy of continuous product research and improvement. We reserve the right to change specifications and product design without notice. Such revisions do not entitle the buyer to corresponding changes, improvements, additions or replacements for previously purchased equipment.

OPTIONS AND ACCESSORIES

- Additional oven rack
- Casters -front two casters lock
- Cable restraint kit (to restrict movement when on casters)
- Open-frame base with casters

**INTENDED FOR COMMERCIAL USE ONLY.
NOT FOR HOUSEHOLD USE.**



1100 Old Honeycutt Road, Fuquay-Varina, NC 27526
(919) 762-1000 www.southbendnc.com