



AC-2

Air Curtain Display Cooler

4094 Paul Buchman Highway
Plant City, FL 33565
800.441.4014 | 813.870.0340
www.excellenceindustries.com

The company reserves the right to change the design and/or specifications of these products without notice. Printed in the USA.
Current version 09.22

KEY ASPECTS

SPECIAL FEATURES:

- GFCI power cord
- Electronic thermostat
- Energy efficient
- Adjustable shelf
- Innovation in small footprint open cooler technology
- High impulse beverage refrigeration

OPTIONS:

- Graphics
- Casters with 2 locking



Complies with 2017 DOE standards for commercial cooler without door

TECHNICAL SUMMARY

MODEL	SIZE	ELECTRICAL			REFRIGERATION			OTHER					
	Dimensions (inches)* Width x Depth x Height	Cubic Feet	Net Weight (lbs.)	Shipping Weight (lbs.)**	Voltage/Hz/Phase	Running Amps	Compressor HP	Refrigerant	Temperature	No. of 8.4 oz cans	No. of 12 oz cans	No. of 16.9 oz bottles	Container Quantity
AC-2	25 7/8 x 16 5/8 x 36	2.4	101	116	115/60/1	2.7	1/4	R-134a	+32°F to +41°F	89	54	40	138

*Dimensions are all nominal lengths

**Does not include weight of pallet when needed

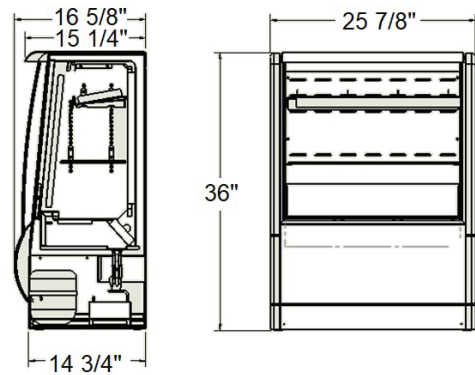

4094 Paul Buchman Highway
 Plant City, FL 33565
 800.441.4014 | 813.870.0340
www.excellenceindustries.com
 ver. 09.22