



PROJECT _____

ITEM NO: _____

QUANTITY: _____

Aluminum Dunnage Rack

FEATURES & CONSTRUCTION:

- Heavy duty fully welded construction with 1- 1/2" square aluminum tubing
- 1-1/2" square aluminum legs with plastic feet
- Weight load capacity up to 2000 Lbs

MATERIAL:

Aluminum 6063-T5



NSF STD.2
Certified

14" Deep Series	UNIT SIZE		
MODEL#	L	D	H
SMADR-14248	24"	14"	8"
SMADR-14368	36"		
SMADR-14488	48"		

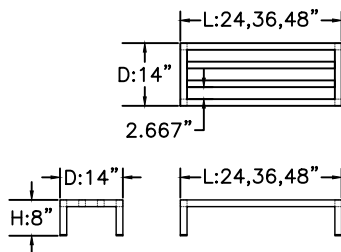

20" Deep Series	UNIT SIZE		
MODEL#	L	D	H
SMADR-20248	24"	20"	8"
SMADR-20368	36"		
SMADR-20488	48"		
SMADR-20608	60"		12"
SMADR-202412	24"		
SMADR-203612	36"		
SMADR-204812	48"		
SMADR-206012	60"		

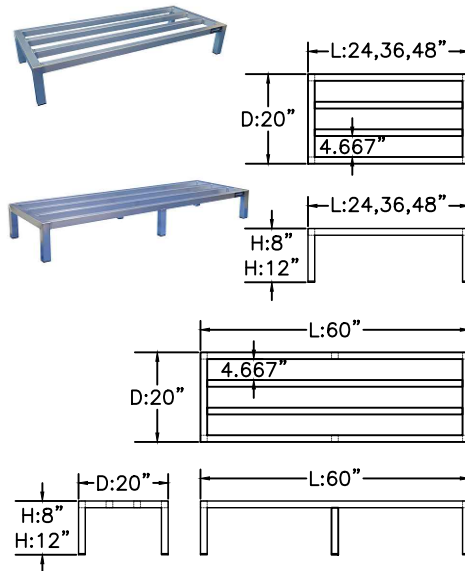

24" Deep Series	UNIT SIZE		
MODEL#	L	D	H
SMADR-242412	24"	24"	12"
SMADR-243612	36"		
SMADR-244812	48"		
SMADR-246012	60"		
SMADR-246012	60"		

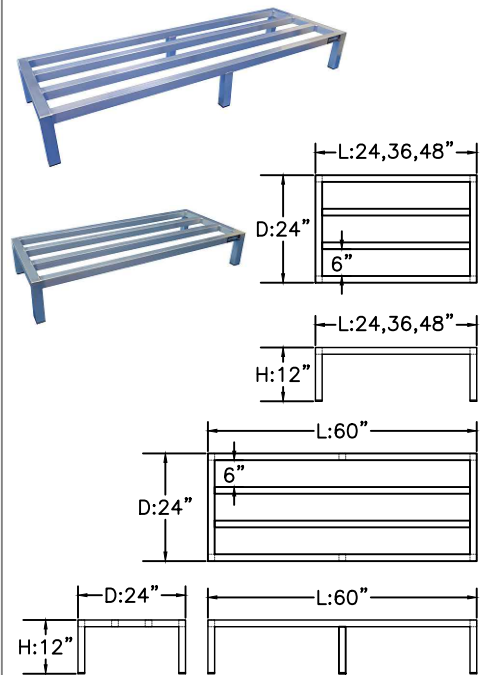

18" Deep Series	UNIT SIZE		
MODEL#	L	D	H
SMADR-18212	24"	18"	12"

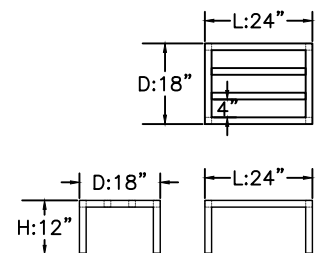

Specifications subject to change without notice.

All dimensions are typical (Tolerance 1/2").



Rev. 11/23

SAPPHIRE MANUFACTURING
Tel: 718-543-2111
Fax: 718-543-2121

info@sapphiremanufacturing.com
WWW.SAPPHIREMANUFACTURING.COM