

# Reveal<sup>®</sup> INSTALLATION & OPERATING MANUAL

SCC P/N  
20-88466

REVEAL<sup>®</sup> SLIDE-IN, DRY (AMBIENT) SERVICE MERCHANDISERS

> UV-BONDED GLASS > ADJUSTABLE SHELVES > REAR SLIDING DOORS

> **CAUTION! DO NOT PUSH OR PULL ON UPPER GLASS ENCLOSURE!**

> **ONLY USE HANDLES (AT EACH END OF CASE) TO PUSH OR PULL CASE INTO POSITION!**

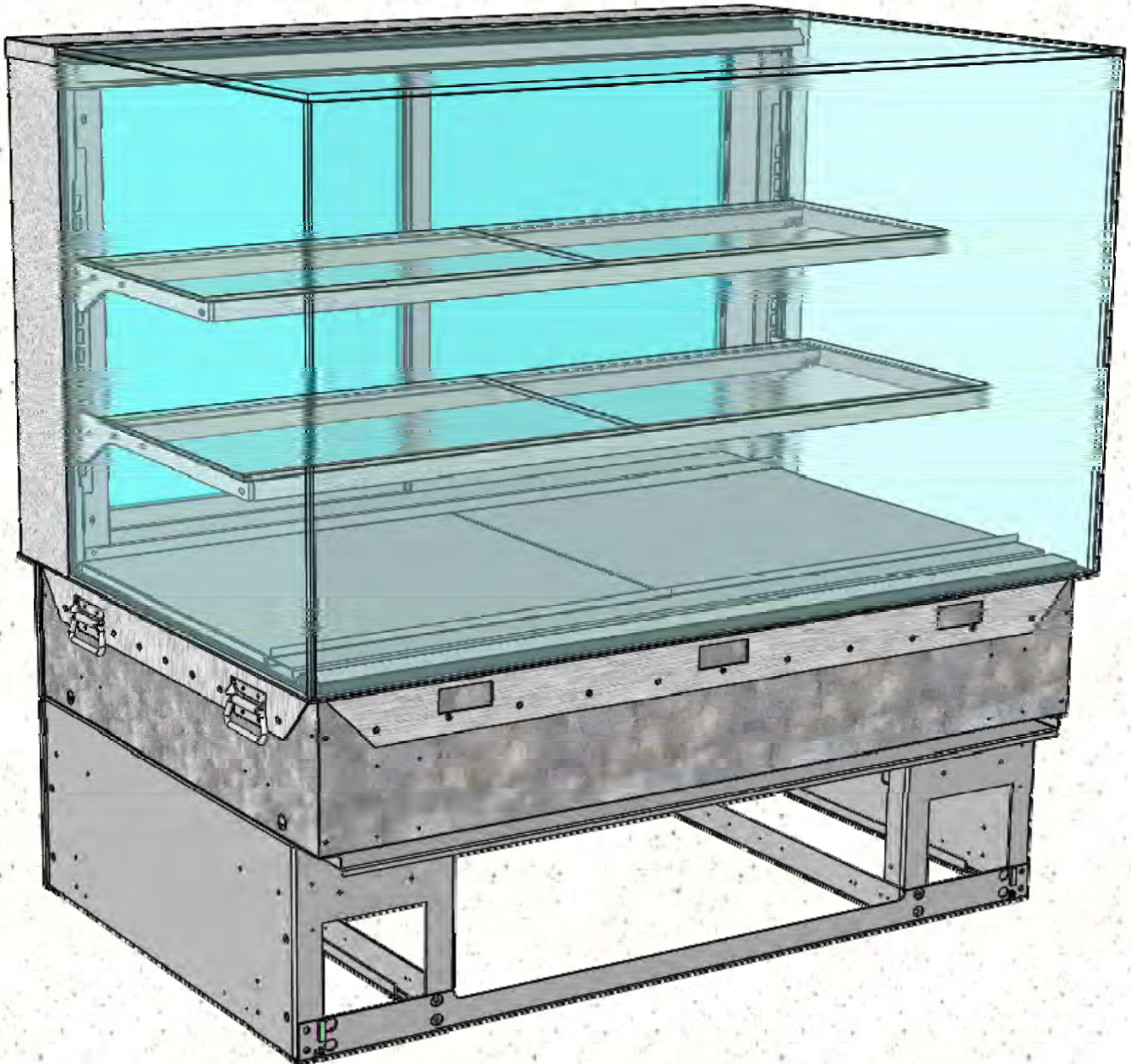

Model NE4827DSV Slide-In Dry  
(Ambient) Service Merchandiser

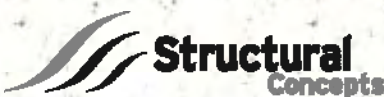

## TABLE OF CONTENTS

<b>TABLE OF CONTENTS .....</b>	<b>2</b>
<b>OVERVIEW / COMPLIANCE / LAMP REPLACEMENT / ELECTRICAL HAZARD WARNING / WIRING DIAGRAM .....</b>	<b>3</b>
<b>WEIGHT LOAD ON GLASS - PREVENTING SAGGING / SEALING COUNTER-MOUNTED UNITS .</b>	<b>4</b>
<b>REVEAL® SLIDE-IN DRY (AMBIENT) SELF-SERVICE MODEL APPLICABILITY &amp; DIMENSIONS..</b>	<b>5</b>
<b>INSTALLATION: TOE-KICK &amp; REAR PANEL REMOVAL / REMOVING CASE FROM PALLET .....</b>	<b>6</b>
<b>INSTALLATION, CONT'D: POSITIONING CASE / HANDLES ON SIDES OF CASE .....</b>	<b>7</b>
<b>INSTALLATION, CONT'D: BUBBLE-WRAPPED GLASS (FOR SHELVING) .....</b>	<b>8</b>
<b>INSTALLATION, CONT'D: SHELVING ASSEMBLY COMPONENTS .....</b>	<b>9</b>
<b>INSTALLATION, CONT'D: PLUG IN UNIT / CASE ENERGIZING / UPPER &amp; LOWER REAR PANELS .....</b>	<b>10</b>
<b>CASE DESIGN: FRONT VIEW OF SLIDE-IN, DRY (AMBIENT) SERVICE MERCHANDISERS .....</b>	<b>11</b>
<b>CASE DESIGN, CONT'D: REAR VIEW OF SLIDE-IN, DRY (AMBIENT) SERVICE MERCHANDISERS .....</b>	<b>12</b>
<b>CASE DESIGN, CONT'D: POWER CORD &amp; PLUG / LED LIGHT SWITCH LOCATION / LED LIGHTS .....</b>	<b>13</b>
<b>CASE DESIGN, CONT'D: REAR SLIDING DOORS / DOOR OPERATION .....</b>	<b>14</b>
<b>CLEANING SCHEDULE (TO BE PERFORMED BY STORE PERSONNEL) .....</b>	<b>15</b>
<b>TROUBLESHOOTING (TO BE PERFORMED BY STORE PERSONNEL) .....</b>	<b>16</b>
<b>TROUBLESHOOTING (TO BE PERFORMED BY TRAINED SERVICE PROVIDERS ONLY) .....</b>	<b>17</b>
<b>SERIAL LABEL INFORMATION &amp; LOCATION .....</b>	<b>18</b>
<b>TECHNICAL SERVICE CONTACT INFORMATION &amp; WARRANTY INFORMATION .....</b>	<b>19</b>

**OVERVIEW**

- Cases should be installed and operated according to this operating manual's instructions to insure proper performance.
- Improper use will void warranty.

**COMPLIANCE**

- Performance issues when in violation of applicable NEC, federal, state and local electrical codes are not covered by warranty.

**LAMP REPLACEMENT PRECAUTIONS**

- Following lamp replacement guidelines can prevent damage to unit.
- Please read carefully!

**ELECTRICAL HAZARD WARNING**

- Please read the electrical hazard warning in this document carefully as it can prevent injury or death.
- Please read carefully!

**WIRING DIAGRAM**

- Each case has its own wiring diagram folded and in a packet.
- Wiring diagram placement may vary (near ballast box, field wiring box, raceway cover, or other related location).



**ATTENTION  
CONTRACTORS**

**COMPLIANCE**  
This equipment **MUST** be installed in compliance with all applicable NEC, federal, state and local electrical codes.



**CAUTION! LAMP REPLACEMENT PRECAUTIONS**  
LED lamps reflect specific size, shape and overall design. Any replacements must meet factory specifications.



**WARNING**  
Risk of electric shock. Disconnect power before servicing unit. **CAUTION!** More than one source of electrical supply is employed with units that have separate circuits. *Disconnect ALL ELECTRICAL SOURCES before servicing.*

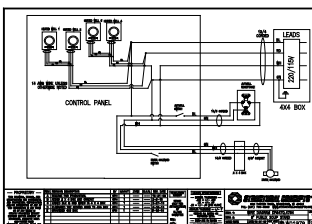

**WIRING DIAGRAM FORMAT & LOCATION**

- Each case has its own wiring diagram folded & in its own packet.
- Wiring diagram placement may vary; it may be placed near field wiring box, raceway, or other related location.

## WEIGHT LOAD ON GLASS - PREVENTING SAGGING / SEALING COUNTER-MOUNTED UNITS

### WEIGHT LOAD ON GLASS / PREVENTING SAGGING

- Caution! To prevent sagging or breakage of glass, do not exceed 5 LB (2.3 KG) weight load per top glass section (between vertical supports).
- To prevent scratching or marring, do not place ANY items on glass.

### SEALING COUNTER-MOUNTED UNITS

- Proper sealing of base support to counter prevents accumulation of dust, residue and liquids as well as insect harborage.
- For sanitation purposes, counter-mounted units must be sealed to counter with silicone that meets or exceeds food grade NSF/ANSI Standard 51.
- Prior to proceeding, thoroughly clean both counter and underside of base support to assure a secure seal.



Base Support Underside



### **CAUTION!**

- To prevent sagging or breakage, do not exceed 5 LBS (2.3 KG) weight load per top glass section (between vertical supports).
- To prevent scratching or marring, do not place ANY items on glass.

### **SEAL COUNTER-MOUNTED UNITS TO COUNTER**

- To assure a secure seal, thoroughly clean both counter and underside of base support prior to proceeding.
- Apply a thin, UNINTERRUPTED bead of silicone to underside of base support before placing into position on counter.
- Silicone must meet or exceed food grade NSF/ANSI Standard 51.



**REVEAL® SLIDE-IN DRY (AMBIENT) SERVICE MODEL APPLICABILITY & DIMENSIONS**

<b>Model</b>	<b>Upper Display Case Height</b>	<b>Overall Case Height</b>	<b>Case Depth x Width</b>
NE3613DSV	13 5/8"	32 7/8"	33"D x 35 3/4"W
NE3620DSV	20 3/8"	39 5/8"	33"D x 35 3/4"W
NE3627DSV	27 7/8"	47 1/8"	33"D x 35 3/4"W
NE3635DSV	35 1/4"	54 5/8"	33"D x 35 3/4"W
NE4813DSV	13 5/8"	32 7/8"	33"D x 47 3/4"W
NE4820DSV	20 3/8"	39 5/8"	33"D x 47 3/4"W
NE4827DSV	27 7/8"	47 1/8"	33"D x 47 3/4"W
NE4835DSV	35 1/4"	54 5/8"	33"D x 47 3/4"W

## INSTALLATION: TOE-KICK & REAR PANEL REMOVAL / REMOVING CASE FROM PALLET

### 1. Remove Toe-Kick From Case

- If present, remove and discard front toe-kick from case before removing from pallet.
- Toe-kick is held in place by magnets only. No screw removal is required.

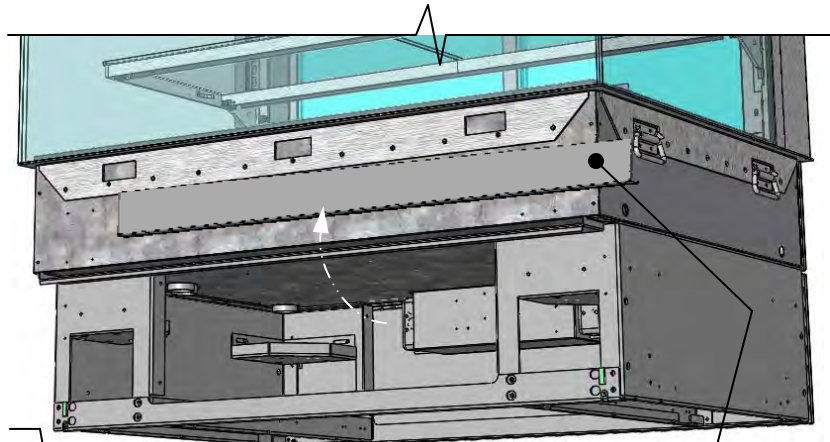

### 2. Remove Lower and Possibly Upper Rear Panels From Case

- Remove lower rear panels to prevent damage to case during pallet removal.
- Drop-in units (vs. slide-in units) require that you ALSO remove upper rear panel to prevent damage to case.
- Also, drop-in units MAY require rear magnets to be removed from rear for case to fit into counter.

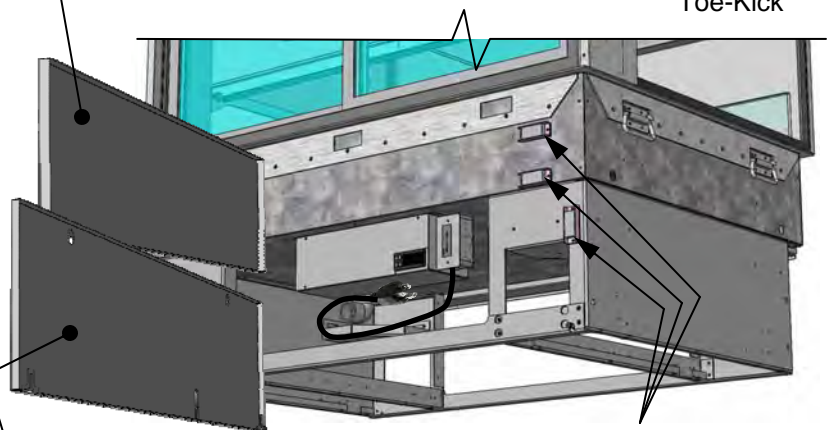

### 3. Disconnect Case From Pallet

- Remove screws from shipping brackets. Remove and discard shipping brackets from pallet.
- Place J-bar/pry under base frame. Raise case up from pallet; remove rubber shipping blocks.

Lower Rear Panel

Shipping Bracket

Pallet

Rubber Shipping Block

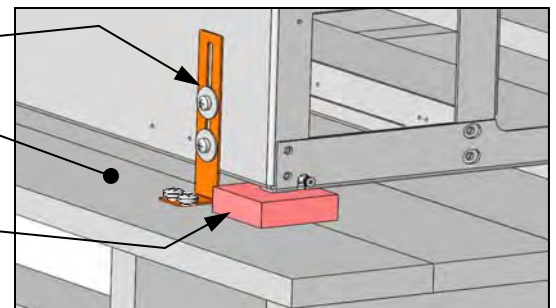

### 4. Carefully Remove Case From Pallet

- Use handles to carefully slide case to rear of pallet (see illustration at right).
- **Caution! 4 people are required for this task!**
- Carefully lower to floor. Slide pallet from under case.
- Maintain support of case at all times or case may fall.

Pallet

Support case while removing from pallet.

Handles

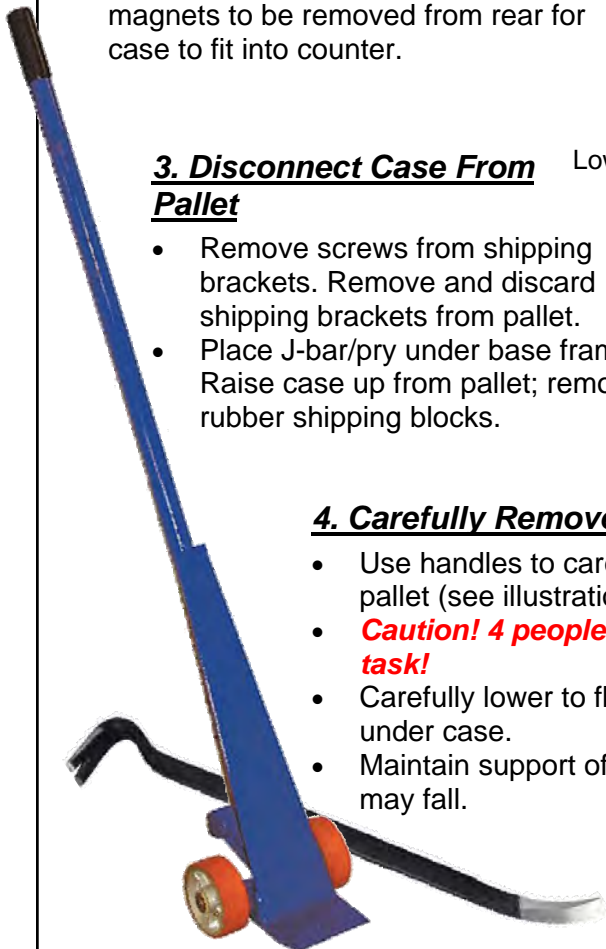
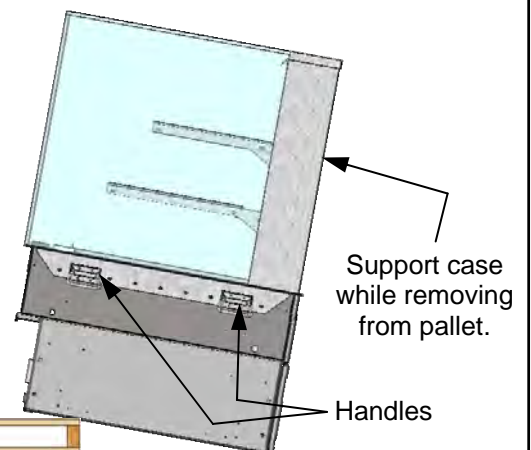

## INSTALLATION, CONT'D: POSITIONING CASE / HANDLES ON SIDES OF CASE

### **5. Prepare Case For Counter: Rear Panels**

- Rear panels must remain OFF case while it is slid in (or dropped into) counter.
- Panels may be damaged if they remain on the case while placed in counter.

### **6. Prepare Case For Counter: Magnets**

> Slide-In Units: Rear magnets may remain on case while SLIDING INTO counters.

> Drop-In Units: Due to space restraints, rear magnets MAY NEED TO BE REMOVED from case for case to fit into counter. Measure carefully!

> Lower set of magnets MAY BE REATTACHED to case to allow lower rear panel to be held in place.

### **7. Prepare Case For Counter: Side Handles**

> Slide-In Units: Side handles MAY remain on case if space allows. Otherwise, remove them.

- See "Space For Countertop" shown in illustration below.
- Keep handles in safe place for future possible relocation use.

> Drop-In Units: Due to space restraints, REMOVE SIDE HANDLES to allow case to fit into counter.

- Keep handles in safe place for possible future use.
- See illustration below.

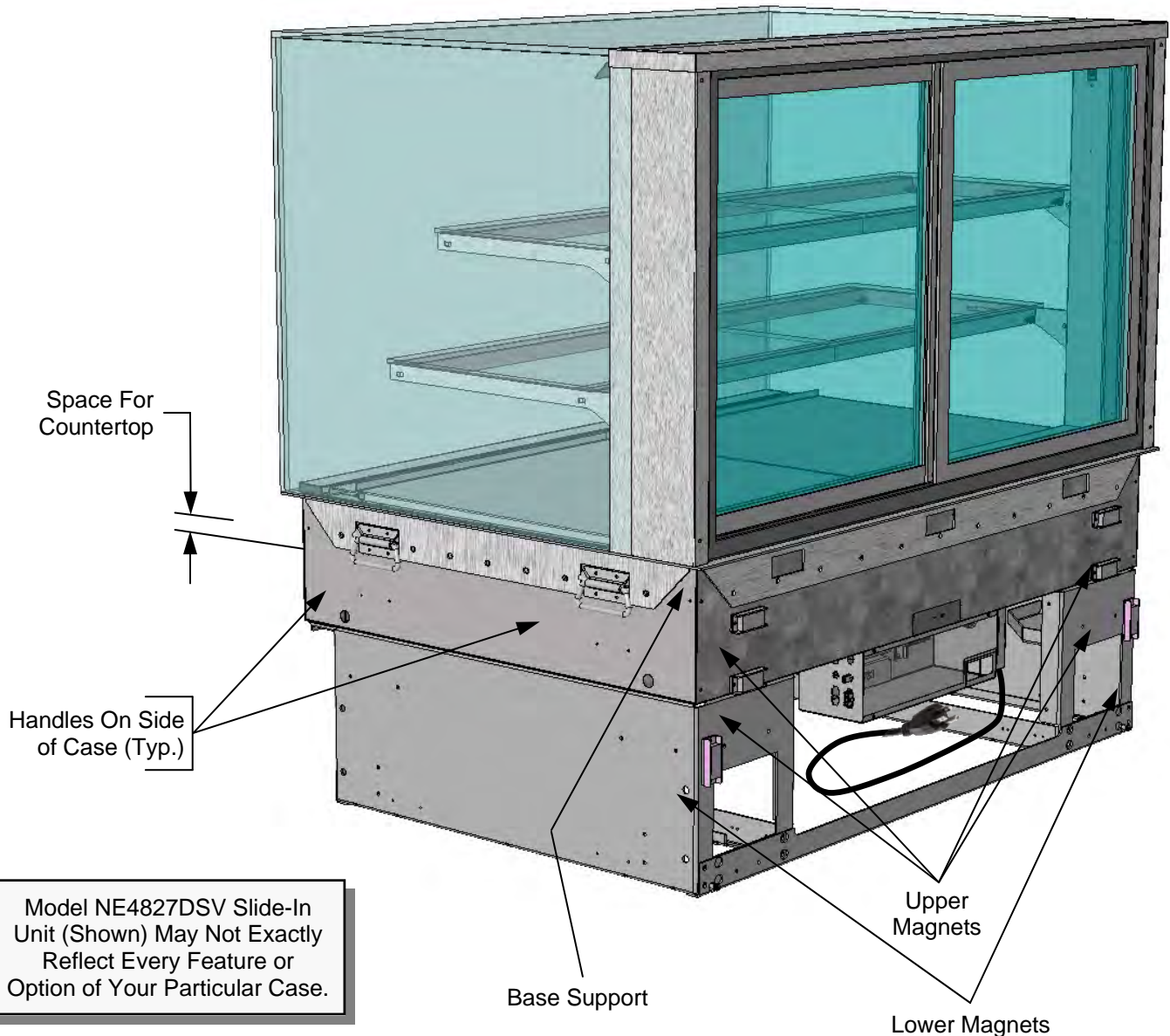

## INSTALLATION, CONT'D: BUBBLE-WRAPPED GLASS (FOR SHELVING)

### **8. Remove Bubble-Wrapped Glass (For Shelving) From Case**

- Carefully remove bubble-wrapped glass shelving pieces from case through rear sliding doors.
- See illustration below-left.

### **9. Remove Glass From Bubble-Wrap / Carefully Place Them On Shelves**

- Remove glass (for shelves) from its bubble-wrap.
- Place glass pieces on shelves.
- Caution! Glass pieces ARE NOT IDENTICAL! Notches on the underside metal covers determine placement in case.
- See illustration below-right and next page.

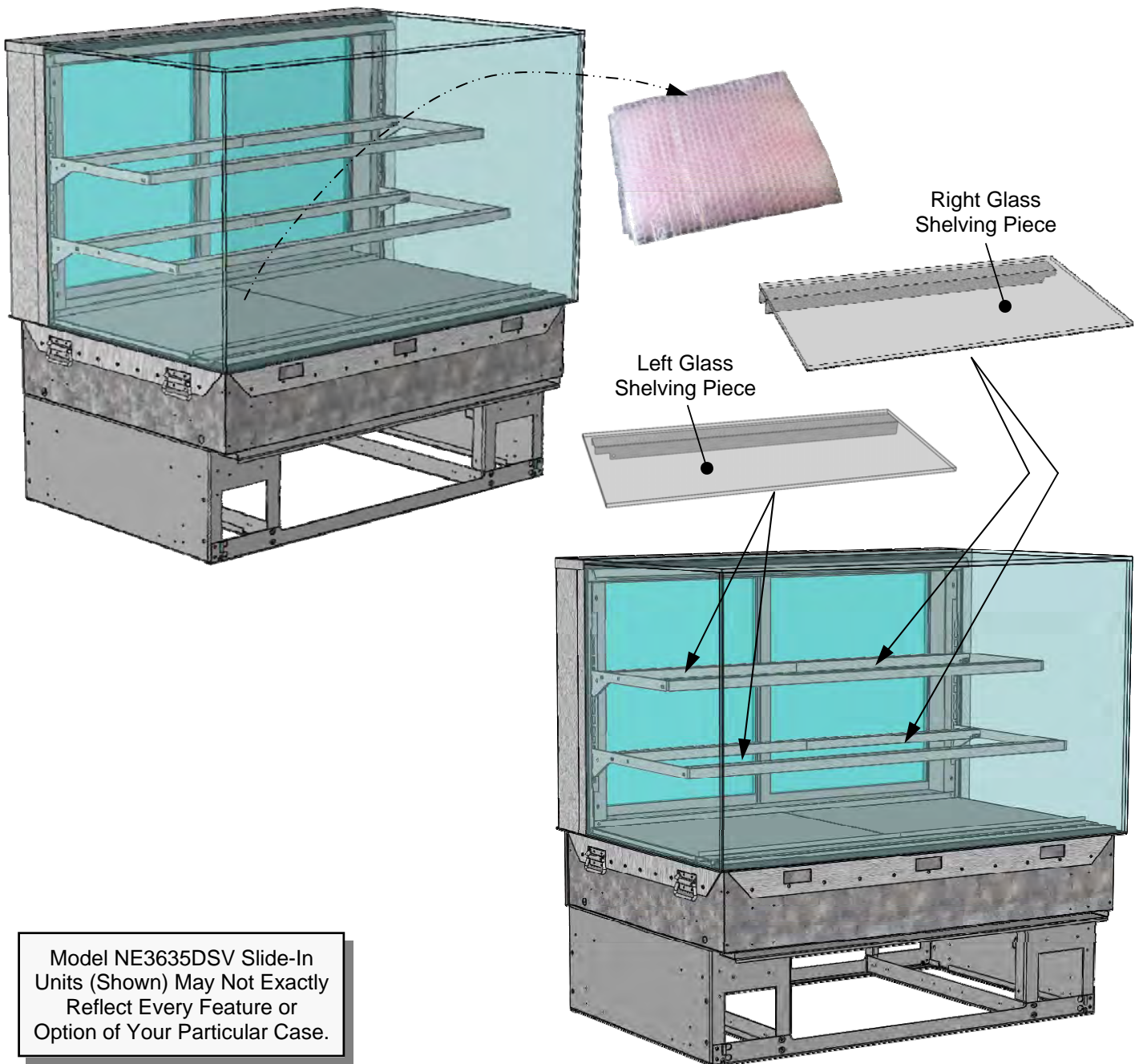

Model NE3635DSV Slide-In Units (Shown) May Not Exactly Reflect Every Feature or Option of Your Particular Case.

**10. Shelving Assembly Components**

- Check that glass shelving is in proper position before placing product in case
  - Shelves may be adjusted vertically or entirely removed from merchandiser.
  - Metal shelving brackets ARE NOT able to be angled. They are at a fixed 90° position.
  - There are 12 components comprising each shelf assembly:
- A. Right bracket (with hooks to attach to slots in upright)
  - B. LED light with magnets
  - C. Front shelf support rail (LED light attaches to its inner cavity via magnets)
  - D. Cover (rests atop front shelf support rail)
  - E. Left bracket (hooks to attach to slots in upright)
  - F. Nylon thumbscrews (4 per shelf) secure shelving during shipment. Note: Remove (using pliers, if

- necessary) and discard thumbscrews after case is installed so shelves can be disassembled (to clean or service).
- G. Rear shelf support rail
  - H. Left and right glass shelf/cover assemblies (glass is affixed to covers with 2-sided tape from factory). Caution! Glass pieces ARE NOT IDENTICAL! Notches on underside metal covers determine placement in case.
  - I. Nylon retainer clips (2 per shelf) secure brackets during shipment. Note: To adjust or remove shelves, you must remove retainers; pliers may be required to accomplish this task.

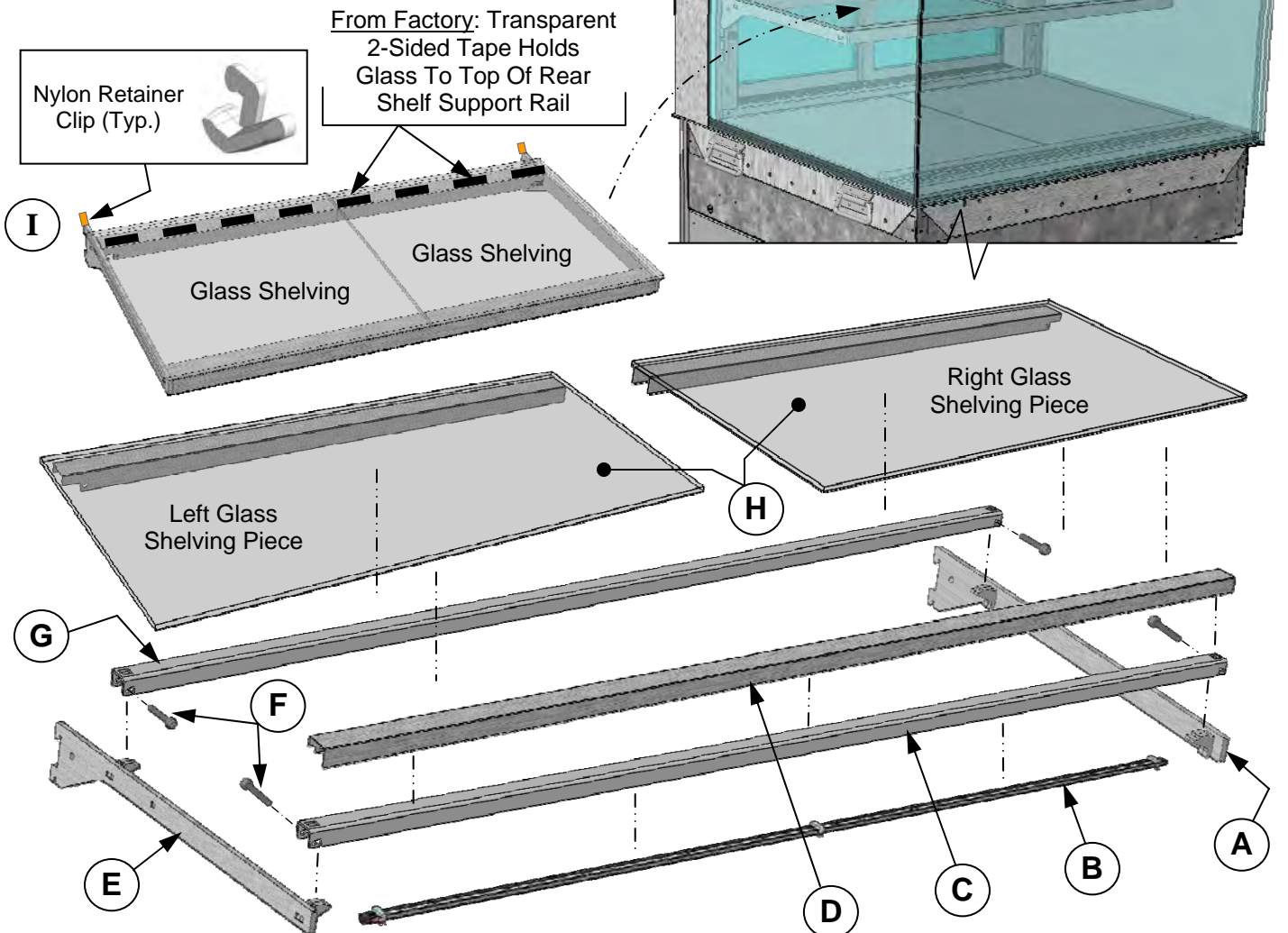

**11. Plug Case In / Case Will Energize**

- Power cord with plug is factory-supplied.
- Plug case into customer-supplied electrical outlet. Case will energize.
- Turn on LED light switch at rear-right upright.
- See illustration at right.

**12. Slide-In Units: Reattach Upper and Lower Rear Panels**

- Rear panels are held in place by magnets.
- Lower rear panel has a slot for power cord.
- See illustration below.

**13. Drop-In Units: Reattach Lower Rear Panel**

- Lower rear panel may be attached to case after it has been dropped in countertop.
- If lower magnets have been removed from case (for drop-in), you must REATTACH them in same position for lower attachment to be held in place.
- Do not return upper rear panel to case.

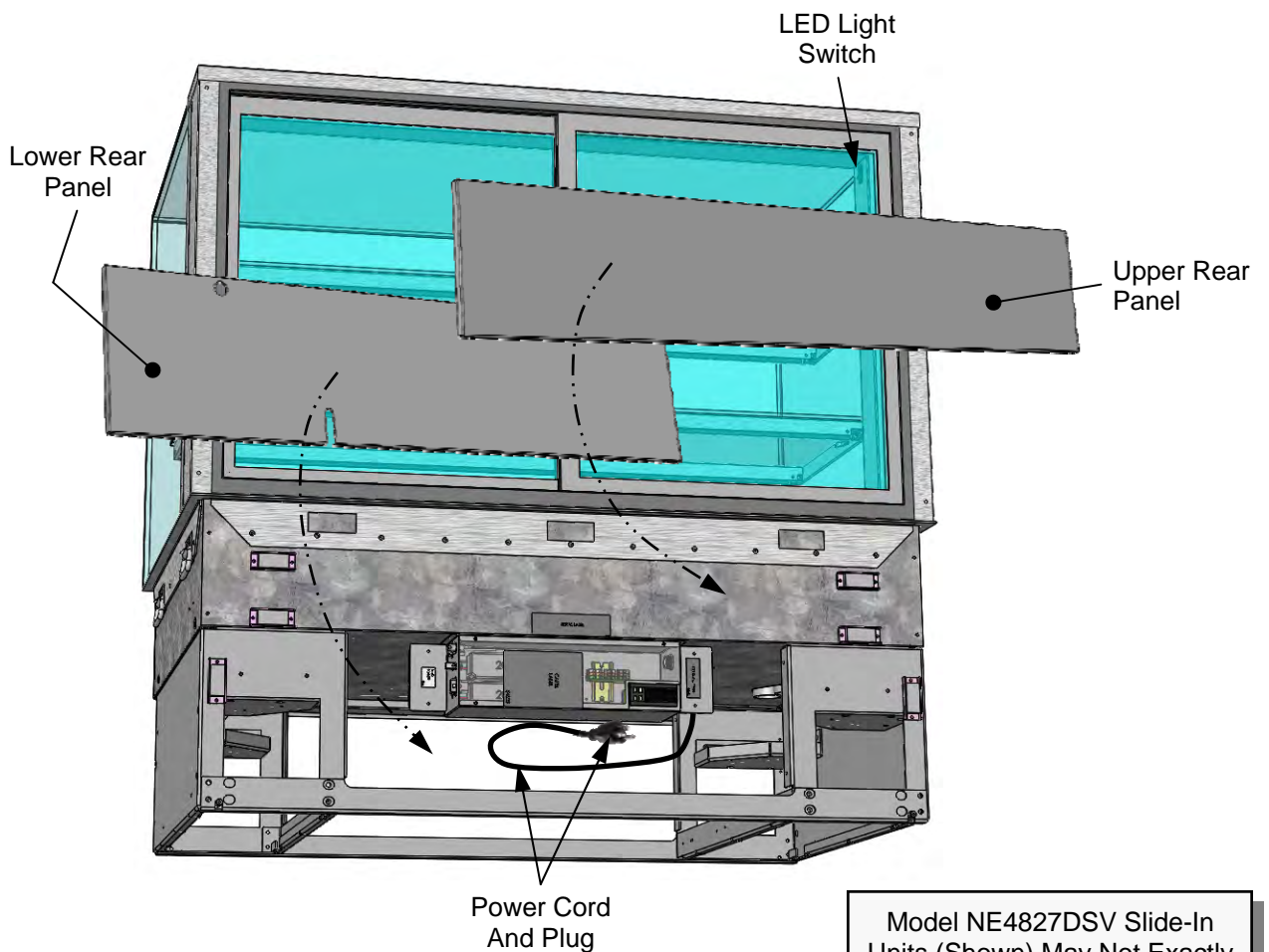

Model NE4827DSV Slide-In Units (Shown) May Not Exactly Reflect Every Feature or Option of Your Particular Case.

## CASE DESIGN: FRONT VIEW OF SLIDE-IN, DRY (AMBIENT) SERVICE MERCHANDISERS

### 1. Case Design: Front View Of Slide-In, Dry (Ambient) Service Merchandisers

- Model NE4827DSV is illustrated below.
- See next page for rear view of merchandiser.

Model NE4827DSV Slide-In Unit (Shown)  
May Not Exactly Reflect Every Feature or  
Option of Your Particular Case.

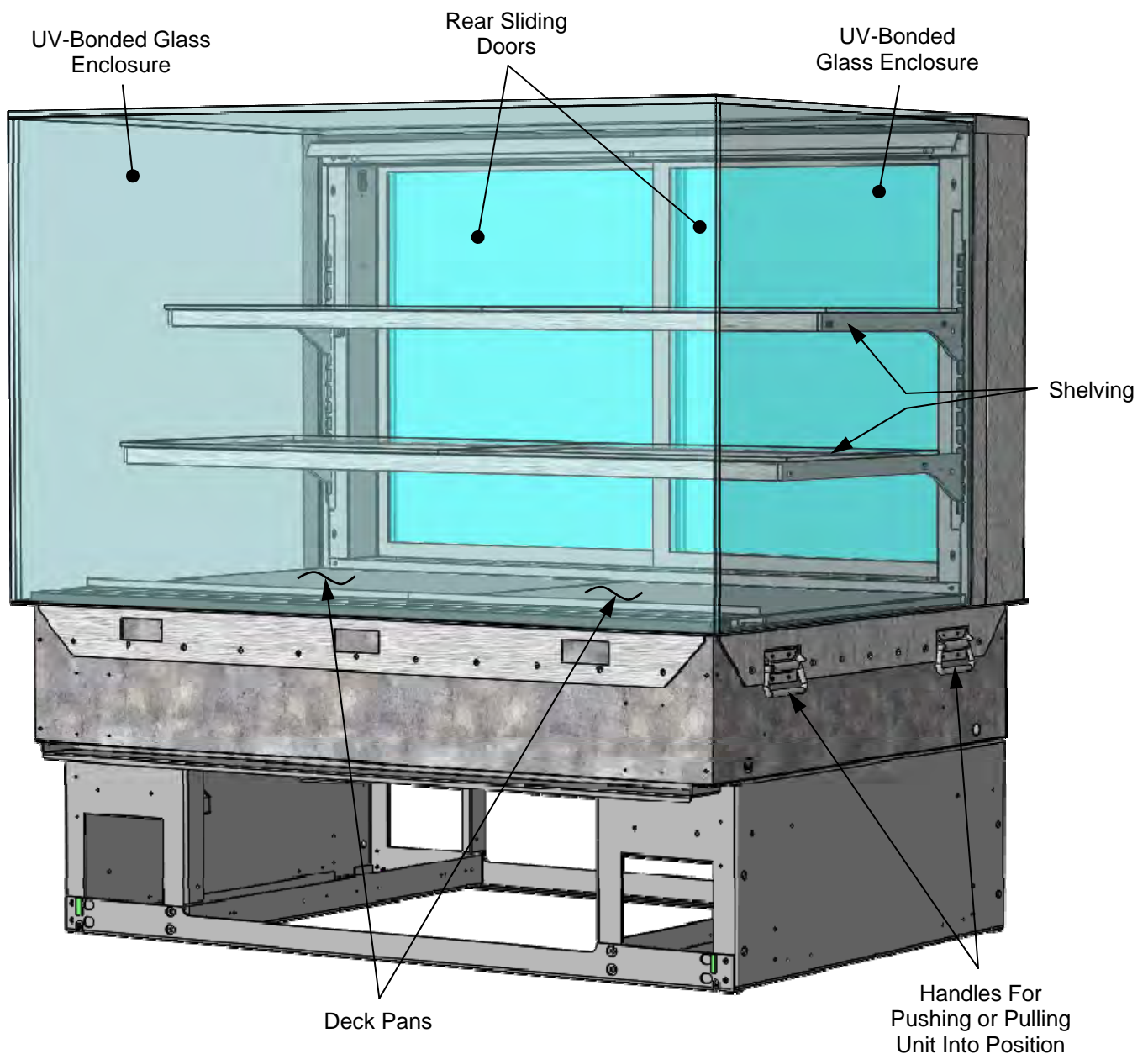

**2. Case Design: Rear View Of Slide-In, Service Merchandisers**

- Model NE4827DSV slide-in unit is illustrated below.
- Handles (at both ends of case) are for pushing/pulling into position.
- See previous page for front view of merchandiser.

Model NE4827DSV Is Shown.  
It May Not Exactly Reflect  
Every Feature or Option Of  
Your Particular Case.

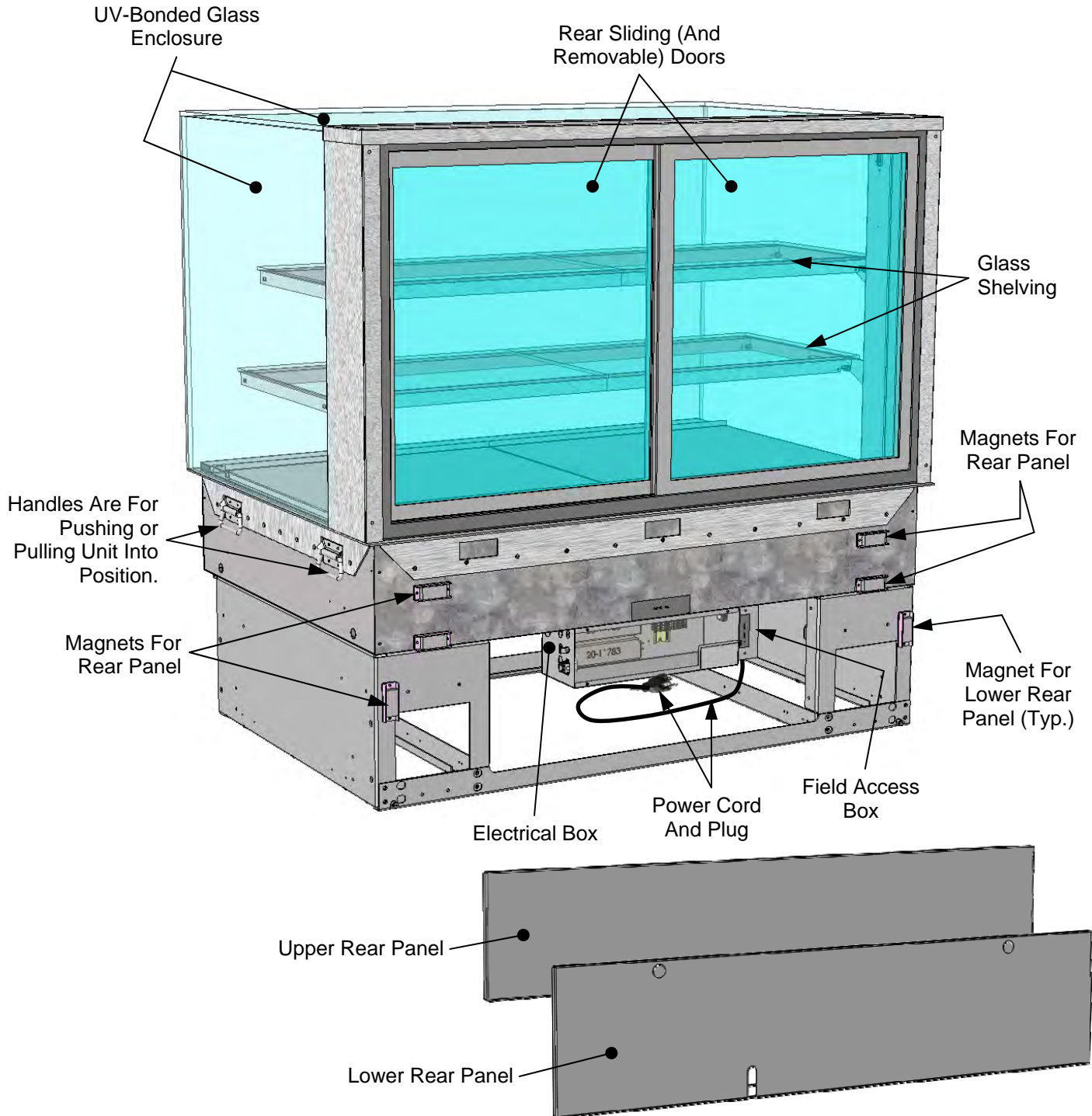

### 3. Power Cord and Plug

- Power cord and plug (for LED lights) is at case rear (shown below).
- Caution! You must plugged in an approved outlet!

### 4. LED Light Switch Location

- Light switch is in column cover (accessible by sliding open door at case rear).
- See illustrations below-right.

### 5. LED Lights

- LED lights are located at both header and shelving of case (as shown below).
- Check that ALL of the light plugs are properly connected to the LED light.
- Plug must be inserted ALL THE WAY into the LED light orifice (with no gap) to work properly.
- See **TROUBLESHOOTING** section in manual if LED lights malfunction.

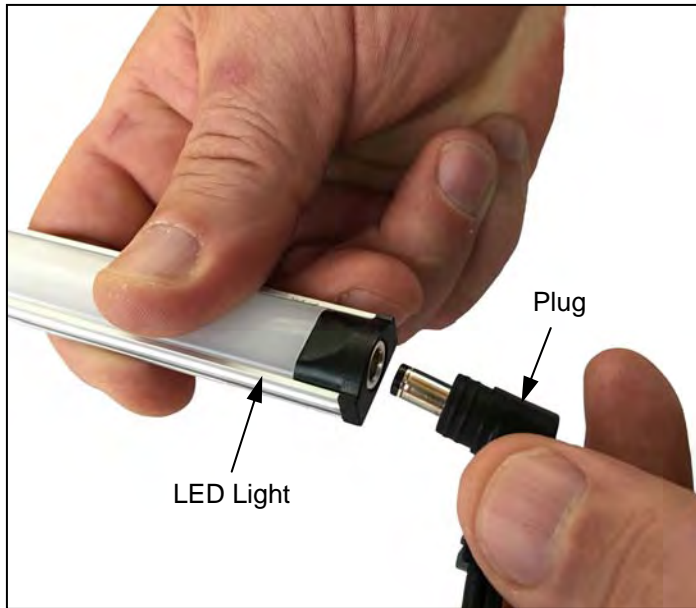

LED Light

Plug

LED Lights In  
Shelving And  
Header

LED Light  
Switch

Rear Sliding  
Doors

Model NE4835DSV  
Countertop Unit (Shown) May  
Not Exactly Reflect Every  
Feature or Option of Your  
Particular Case.

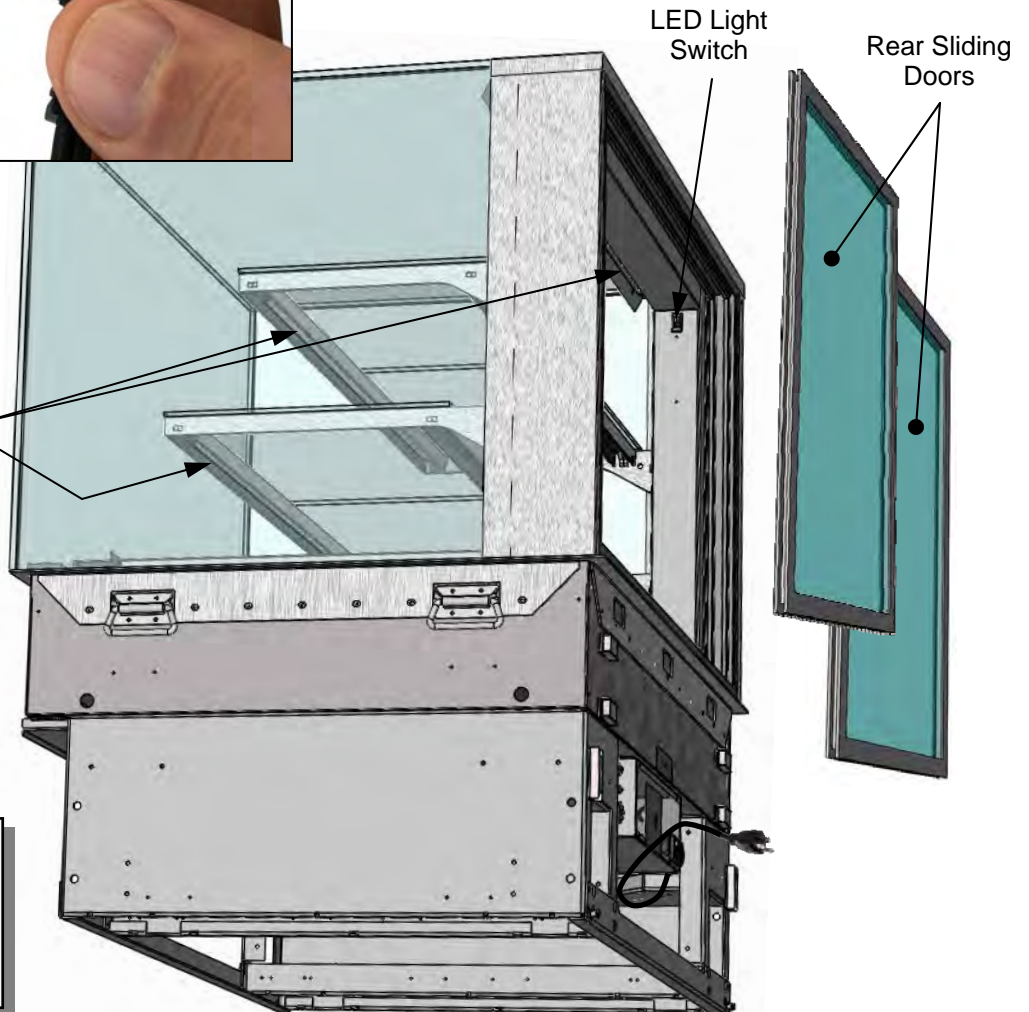

**6. Rear Sliding Door Removal / Replacement**

- To remove rear sliding doors, move doors toward center of case.
- Individually lift each door up toward the top of the case; pivot the bottom of the door out.
- Return doors to case in reverse order they were removed.

Model NE4835DSV  
Countertop Unit (Shown) May  
Not Exactly Reflect Every  
Feature or Option of Your  
Particular Case.

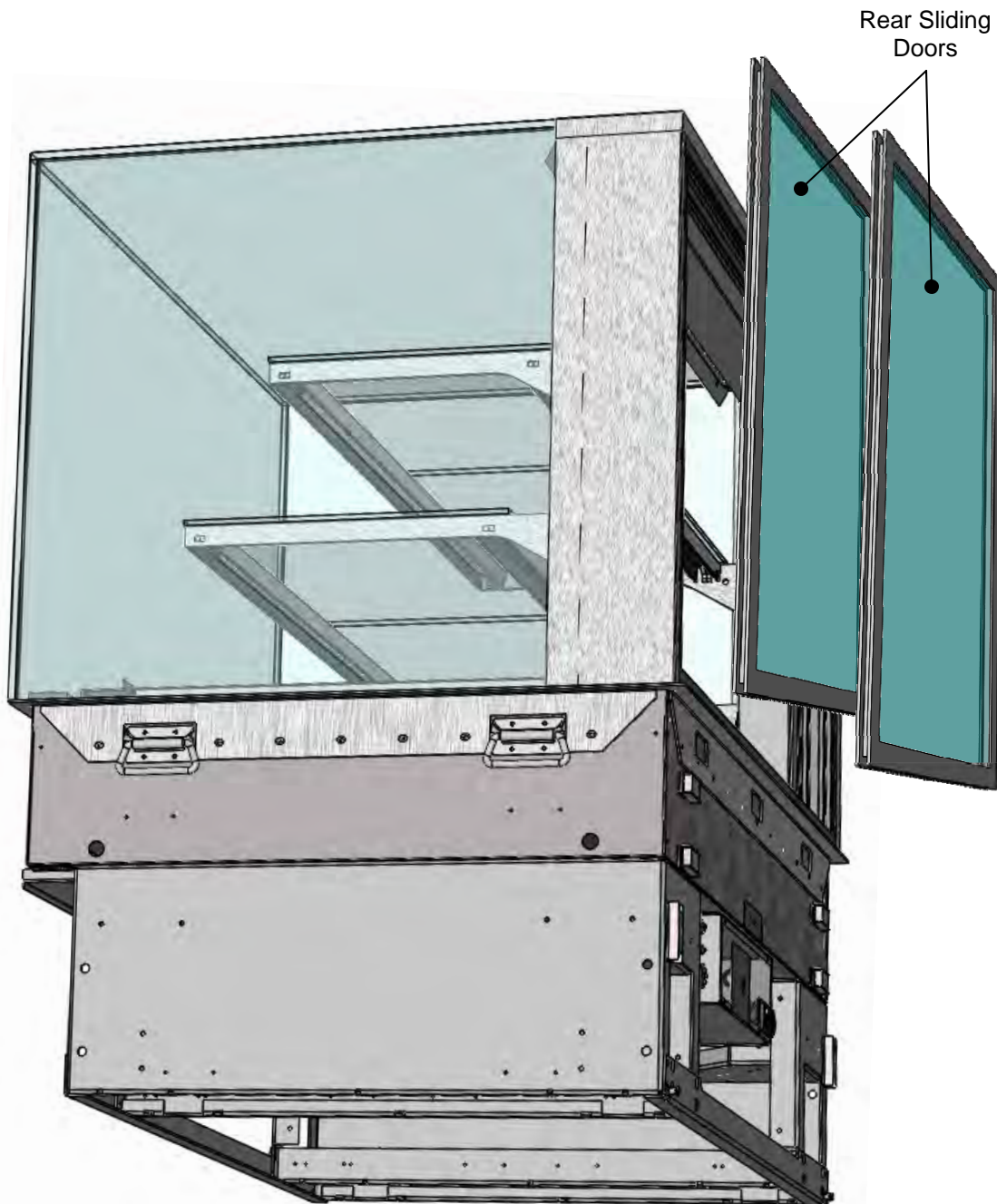

**CLEANING SCHEDULE (TO BE PERFORMED BY STORE PERSONNEL)**

FREQUENCY	INSTRUCTIONS
Daily	<b><u>Glass Surfaces:</u></b> Clean side glass and shelves with household or commercial glass cleaner.
Daily	<b><u>Rear Sliding Door Glass:</u></b> Clean with household or commercial glass cleaner. Clean out rear door track with moist cloth.
Daily	<b><u>End Panels, Front Panel, Toe-Kick, etc.:</u></b> Wipe off all surfaces with warm water and mild soap solution and non-abrasive cloth.
Daily	<b><u>Decks:</u></b> Wipe off decks with moist cloth dipped in mild soap and water solution.
Daily	<b><u>Stainless Steel Surfaces:</u></b> <ul style="list-style-type: none"> <li>• Wash with a solution of hand dishwashing liquid detergent and water, or a solution of baking soda and water. Rinse and polish dry with paper towel or soft cloth.</li> <li>• Never use scouring powders or steel wool as they will scratch stainless steel.</li> <li>• Brighten by polishing with a cloth dipped in vinegar or in ammonia; sprinkle baking soda on sponge and rub gently; rinse. Polish dry with paper towel.</li> <li>• Remove streaks or heat stains from stainless steel by rubbing with club soda.</li> </ul>
Quarterly	<b><u>Under Case Cleaning:</u></b> <ul style="list-style-type: none"> <li>• Lower rear panel is held in place with magnets and is removable <u>without tools</u>.</li> <li>• Remove lower rear panel by lifting up and off case. Use vacuum with brush extension to remove all dust, dirt, food particles or residue at underside of case.</li> <li>• Replace lower rear panel when cleaning process is complete.</li> </ul>

## TROUBLESHOOTING (TO BE PERFORMED BY STORE PERSONNEL)

CONDITION	TROUBLESHOOTING
<b>Case Lights Not Working</b>	Check that light switch is in the <i>ON</i> position. <ul style="list-style-type: none"> <li>• See <b>CASE DESIGN, CONT'D: POWER CORD &amp; PLUG / LED LIGHT SWITCH LOCATION / LED LIGHTS</b> section in manual for switch location (regardless of case design).</li> </ul>
	If case is not hard-wired, check that power cord is properly connected to wall outlet.
	Check that ALL of the light plugs are properly connected to the LED light. <ul style="list-style-type: none"> <li>• Plug must be inserted ALL THE WAY into the LED light orifice (with no gap).</li> <li>• See illustrations below-left.</li> </ul>
	Power may not be reaching the case. <ul style="list-style-type: none"> <li>• Contact store management to have trained service provider perform troubleshooting.</li> <li>• Troubleshooting to be performed by trained service providers only is on next page.</li> </ul>
	If case light still do not come on, it may need to be replaced. <ul style="list-style-type: none"> <li>• Contact Structural Concepts' Technical Service Department for replacement light (see <b>TECHNICAL SERVICE</b> section of this manual for contact information).</li> <li>• To replace, disconnect plug from existing LED light. Disconnect LED light from its brackets. Replace with new LED light. Insert plug ALL THE WAY into LED light orifice.</li> </ul>

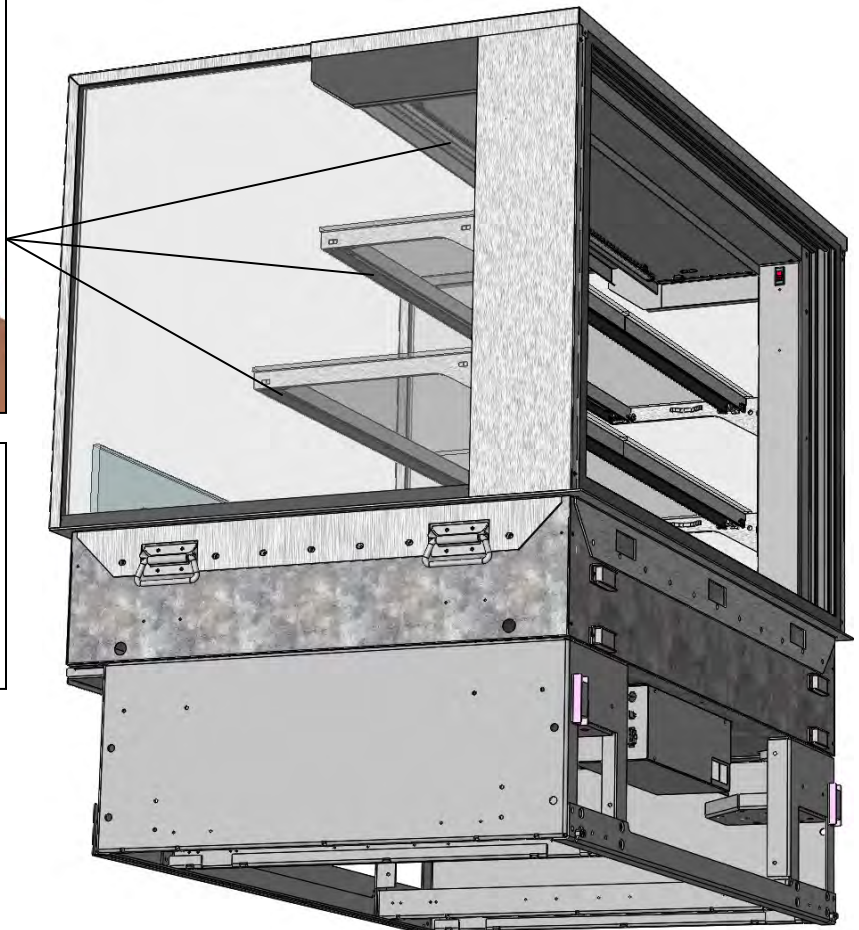
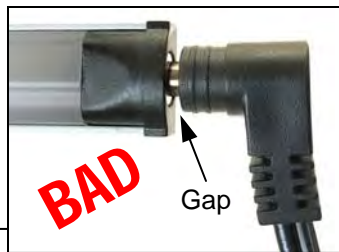
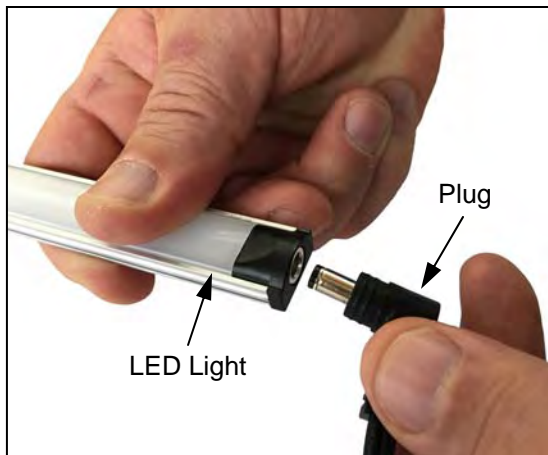

**TROUBLESHOOTING (TO BE PERFORMED BY TRAINED SERVICE PROVIDERS ONLY)**

CONDITION	TROUBLESHOOTING
<b>Case Lights Are Not Working</b>	See <b><i>TROUBLESHOOTING (TO BE PERFORMED BY STORE PERSONNEL)</i></b> section in manual (previous sheet) for most common troubleshooting solutions.
	Check power. <ul style="list-style-type: none"><li>• If power is not supplied to the case, facility may have faulty power distribution.</li><li>• If power is supplied to the case but lights are not energized, case's power supply may be faulty.</li></ul>

**Serial Label Location & Information Listed / Technical Information & Service**

- Serial labels are located near the electrical access on your case.
- Serial labels contain electrical information, as well as regulatory standards to which the case conforms.
- For additional technical information and service, see the *TECHNICAL SERVICE* page in this manual for instructions on contacting Structural Concepts' Technical Service Department.
- See images below for sample dry (ambient) merchandiser label.

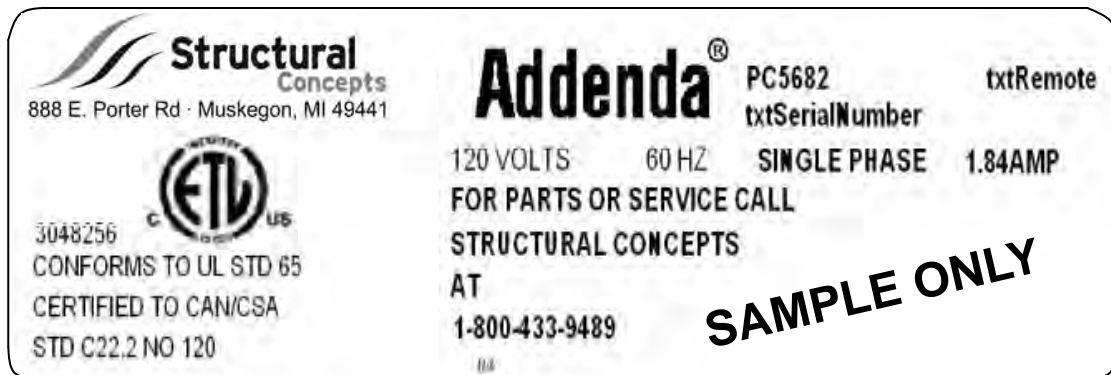

----- Sample Serial Label For Dry (Ambient) Case -----

## SCC TECHNICAL SERVICE CONTACT INFORMATION & WARRANTY INFORMATION

### TECH SERVICE/WARRANTY CONTACT INFO:

1 (800) 433-9490 / EXTENSION 1

### DAYS/HOURS AVAILABLE:

MONDAY - FRIDAY (CLOSED HOLIDAYS)

8:00 a.m. TO 5:00 p.m. EST

### PLEASE HAVE THE FOLLOWING INFORMATION AVAILABLE BEFORE CONTACTING SCC:

SERIAL NO. / MODEL NO. / STORE NO. / STORE ADDRESS / DETAILS (PHOTOS, LEAK LOCATIONS, DAMAGE, STORE'S AMBIENT CONDITIONS, ETC.)

# LIMITED WARRANTY

All sales by Structural Concepts Corporation (SCC) are subject to the following limited warranty. "Goods" refers to the product or products being sold by SCC.

**Warranty Scope:** Warranty is for equipment sold in the United States, Canada, Mexico and Puerto Rico. Equipment sold elsewhere may carry modified warranty.

**Warranty; Remedies; Limitations:** The limit of liability of SCC toward the exchange cost of the original compressor motor (and/or any other components) is one year parts and labor. If any Goods are found to be of faulty material or workmanship within one year of the original F.O.B. unit shipment, SCC will, at its option (after inspection by an authorized representative), replace or pay the reasonable cost of replacement of the faulty Goods. If warranty claim is not made within this one year time period, SCC is not bound to warrant Goods. A motor-compressor (and/or any other components) replaced during the warranty shall not exceed manufacturer's current established wholesaler's exchange price. If replacement motor-compressor (and/or other components) is available via storage facility, parts truck, etc., SCC mandates that readily accessible replacement components be used toward repair of Goods; in such instances, SCC will replace such equipment (at its own expense) after confirmation of its use/placement on defective unit. SCC shall not be charged an additional fee, up-charge or expense for such replacement Goods. If SCC is unable to repair or replace the defective Goods, SCC shall issue a credit to the Purchaser for full or partial purchase price, as SCC shall determine. The replacement or payment in the manner described above shall be the sole and exclusive remedy to Purchaser for a breach of this warranty. If any Goods are defective or fail to conform to this warranty, SCC will furnish instructions for their disposition. No Goods shall be returned to SCC without its prior consent.

SCC's liability for any defect in the Goods shall not exceed the purchase price of the Goods. SCC SHALL HAVE NO LIABILITY TO PURCHASE FOR CONSEQUENTIAL DAMAGES OF ANY KIND WHATSOEVER, INCLUDING, BUT NOT LIMITED TO, PERSONAL INJURY, PROPERTY DAMAGE, LOST PROFITS, OR OTHER ECONOMIC INJURY DUE TO ANY DEFECT IN THE GOODS OR ANY BREACH OF SCC. SCC SHALL NOT BE LIABLE TO THE PURCHASER IN TORT FOR ANY NEGLIGENT DESIGN OR MANUFACTURE OF THE GOODS, OR FOR THE OMISSION OF ANY WARNING THEREFROM.

SCC shall have no obligation or liability under this warranty for claims arising from any other party's (including Purchaser's) negligence or misuse of the Goods or environmental conditions. This warranty does not apply to any claim or damage arising for or caused by improper storage, handling, installation, maintenance, or from fire, flood, accidents, structural defects, building settlement or movement, acts of God, or other causes beyond SCC's control.

Except as expressly stated herein, SCC makes no warranty, express, implied, statutory or otherwise as to any parts or goods not manufactured by SCC. SCC shall warrant such parts or Goods only (I) against such defects, (II) for such periods of time, and (III) with such remedies, as are expressly warranted by the manufacturer of such parts or Goods. Notwithstanding the foregoing, any warranty with respect to such parts or Goods and any remedies available as a result of a breach thereof shall be subject to all of the procedures, limitations, and exclusions set forth herein.

THE WARRANTIES HEREIN ARE IN LIEU OF ALL WARRANTIES, EXPRESS, IMPLIED, STATUTORY, OR OTHERWISE. IN PARTICULAR, SCC MAKES NO WARRANTY OF MERCHANTABILITY OR FITNESS FOR A PARTICULAR PURPOSE.

No representative, agent or dealer of SCC has authority to modify, expand, or extend this Warranty, to waive any of the limitations or exclusions, or to make any different or additional warranties with respect to Goods.

**Period of Limitations:** No claim, suit or other proceeding may be brought by Purchaser for any breach of the foregoing warranty or this Agreement by SCC or in any way arising out of this Agreement or relating to the Goods after one year from the date of the breach. In the interpretation of this limitation on action for a breach by SCC, it is expressly agreed that there are no warranties of future performance of the goods that would extend that period of limitation herein contained for bringing an action.

**Indemnifications:** Purchaser agrees to indemnify, hold harmless, and defend SCC if so requested, from any and all liabilities, as defined herein, suffered, or incurred by SCC as a result of, or in connection with, any act, omission, or use of the Goods by Purchaser, its employees or customers, or any breach of this Agreement by Purchaser. Liabilities shall include all costs, claims, damages, judgments, and expenses (including reasonable attorney fees and costs).

**Remedies of SCC:** SCC's rights and remedies shall be cumulative and may be exercised from time to time. In a proceeding or action relating to the breach of this Agreement by Purchaser, Purchaser shall reimburse SCC for reasonable costs and attorney's fees incurred by SCC. No waiver by SCC of any breach of Purchaser shall be effective unless in writing nor operate as a waiver of any other breach of the same term thereafter. SCC shall not lose any right because it has not exercised it in the past.

Applicable Law. This Agreement is made in Michigan; it is governed by and interpreted according to Michigan law. Any lawsuit arising out of this Agreement or the Goods may be handled by a federal or state court whose district includes Muskegon County, Michigan, and Purchaser consents that such court shall have personal jurisdiction over Purchaser.

**LED Lighting Components Within Lighting System: Retail:** 5-year LED warranty from date of shipment. **Foodservice:** 2-year LED warranty from date of shipment. After one year, warranty does not include labor or other costs incurred for diagnosing, repairing, removing, installing, shipping, servicing, or handling of either defective part or replacement parts. The remedy of repair or provision of a replacement part without charge shall be the exclusive remedy for any warranty claim. The replacement LED and/or power supply assumes the unused portion of warranty remaining on unit(s). A 90-day warranty will apply for any LED sold as a service part. Warranty claim must include serial and model number of unit as well as date code on defective LED lighting component(s). Manufacturer may request return of defective part(s) at customer's expense to initiate claim.

**Glass Material:** Glass (UV-bonded glass, glass sneeze guards, glass enclosures, glass held in place via posts, etc.) is only warranted to FIRST POINT OF DELIVERY.

**Miscellaneous:** If any provision of this Agreement is found to be invalid or unenforceable under any law, the provision shall be ineffective to that extent and for the duration of the illegality, but the remaining provisions shall be unaffected. Purchaser shall not assign any of its rights nor delegate any of its obligations under this Agreement without prior written consent of SCC. This Agreement shall be binding upon and inure to the benefit of SCC and Purchaser and each of their legal representatives, successors and assigns. SCC warrants its products to be free of defects in materials and workmanship under normal use and service for a period of one (1) year from the date of delivery.

This warranty is extended only to the original purchaser for use of the Goods. It does not cover normal wear parts such as plastic tongs, tong holders, tong cables, bag holders, or acrylic dividers.

**General Conditions:** All service labor and/or parts charges are subject to approval by SCC. Contact the Customer Service Department in writing or call 231-798-8888.

All claims must contain the following information: (1) model & serial code number of equipment; (2) the date and place of installation; (3) the name and address of the agency which performed the installation; (4) the date of the equipment failure; and (5) a complete description of the equipment failure and all circumstances relating to that failure.

Once the claim has been determined to be a true warranty claim by SCC's Customer Service Department, the following procedure will be taken: (1) replacement parts will be sent at no charge from SCC on a freight prepaid basis; (2) reimbursement for service labor will be paid if the following conditions have been met - (a) prior approval of service agency was awarded from the Customer Service Department; and (b) an itemized statement of all labor charges incurred is received by the Customer Service Department. The cost of the service labor reimbursement will be based on straight time rates and reasonable time for the repair of the defect.

If problems occur with any compressor, notify SCC's Customer Service Department immediately. Any attempt to repair or alter the unit without prior consent from the Customer Service Department will render any warranty claim null and void. This warranty and protection plan does not apply to any condensing unit or any part thereof which has been subject to accident, negligence, misuse, or abuse, or which has not been operated in accordance with the manufacturer's recommendations or if the serial number of the unit has been altered, defaced, or removed.

**One Year Limit of Liability:** After SCC's one-year parts and labor warranty on the original F.O.B. unit has expired, SCC is not liable for either the equipment or labor costs of repairing or replacing the motor compressor, nor any other components that were included in the original F.O.B. unit.