

ScrapMaster® Model SM & Model PSM

Scrapping, Pre-flushing and Food Waste Disposing System

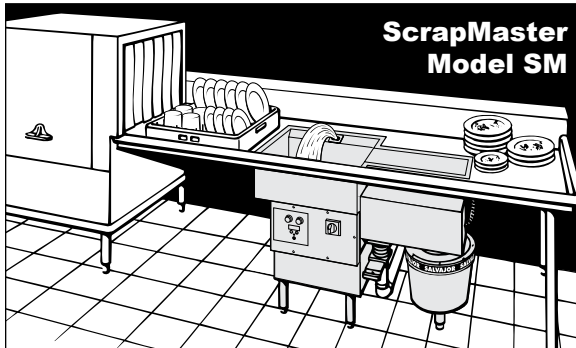

**ScrapMaster
Model SM**

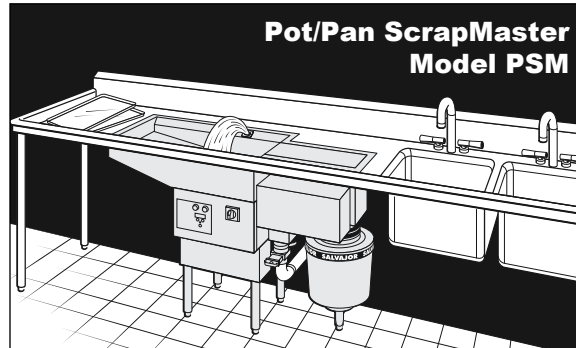

**Pot/Pan ScrapMaster
Model PSM**

**Models Available:
300-SM, 500-SM**

**Models Available:
300-PSM, 500-PSM**

2	Fabricator Instructions & Attaching Disposer
3	Plumbing & Electrical
4	Operating Instructions
5	Troubleshooting
6	How it Works
7	Warranty
8	General Terms and Condition of Sale

ALL INSTALLATIONS SHOULD BE MADE IN ACCORDANCE WITH LOCAL AND NATIONAL PLUMBING AND ELECTRICAL CODES.



U.S. Pat. No. 7,815,134

FOR PRODUCT/WARRANTY REGISTRATION

- Go to www.salvajor.com
- Click on SUPPORT at the top of homepage
- Click on PRODUCT REGISTRATION

SALVAJOR®

Manufacturers of Commercial Food Waste Solutions - Since 1944

4530 East 75th Terrace Kansas City, MO 64132-2081, USA
Toll Free: 1.888.725.8256 | Fax: 1.800.832.9373
service@salvajor.com | www.salvajor.com

Installation & Operating
INSTRUCTIONS

Fabricator Instructions

SM - TABLE CUTOUT DETAIL

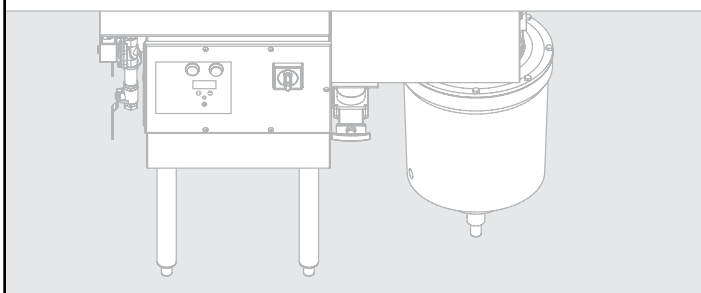
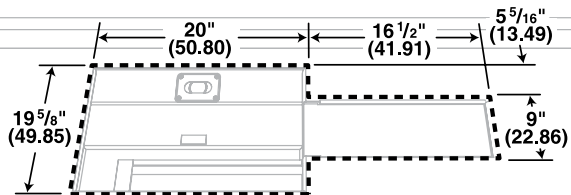

Weld the ScrapMaster into the table using the above dimensions for the table cutout. It is important to locate the ScrapMaster a minimum of 24 inches away from the loading end of the warewasher to allow space for a dish rack.

PSM - TABLE CUTOUT DETAIL

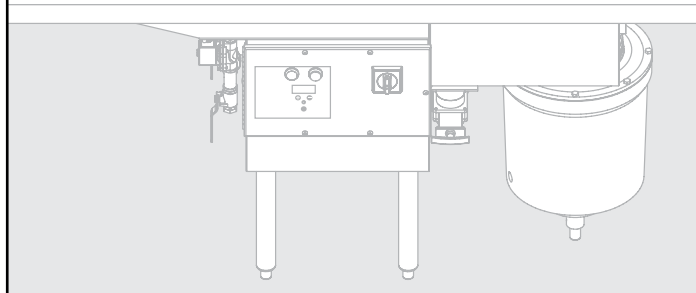
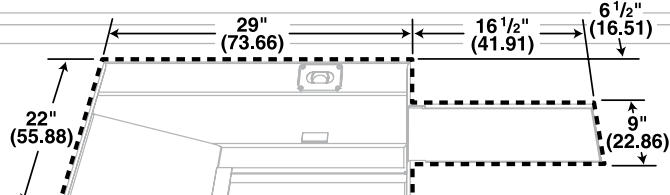

Weld the Pot/Pan ScrapMaster into the table using the above dimensions for the table cutout. It is important to locate the Pot/Pan ScrapMaster a minimum of 24 inches away from the loading end of the warewasher to allow space for a dish rack.

Attaching Disposer

- Carefully remove the top housing assembly by removing the eight bolts making sure not to damage the center gasket.
- Apply lubricant to the rubber collar on the top housing and the beaded collar on the transition of the ScrapMaster.
- Install the top housing assembly up onto the beaded collar and tighten the clamp so the top housing assembly can not be pulled down over the bead. Cut the rubber baffles out of the hycar adaptor to reduce bridging of food waste.
- Measure distance from the bottom of the top housing to floor.
- Turn the disposer on its side and install the leg support on the bottom of the disposer and adjust the leg extension so the disposer will stand approximately 1/2" below the bottom of the top housing.
- Carefully balancing the disposer on the leg support, place it under the top housing, aligning the ears on the shredder ring with the locking tabs of the top housing.
- Slide the center gasket into place. Insert the top housing bolts through holes in the top housing and into the disposer body housing. As you tighten bolts, the disposer will pull up securely to the top housing. Extend the leg extension securely on the floor, and tighten set screws.
- If disposer drain orientation is incorrect loosen top clamp and rotate disposer to correct location.

NOTE: It is important that the leg fit tightly between the disposer and the floor.

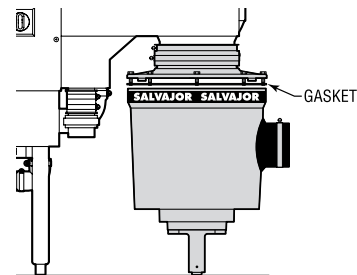
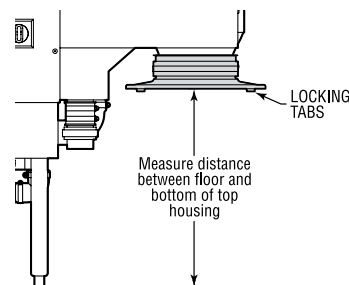
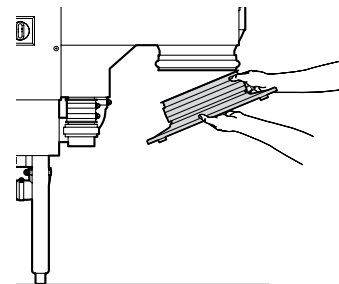

STOP! If you have any questions about this installation call 1-888-SALVAJOR for installation advice.

Plumbing

WATER SUPPLY

Plumb 3/4" lines from both hot and cold water supply sources and reduce to 1/2" before attaching to corresponding valves on the ScrapMaster water harness as shown.

IMPORTANT:

The Salvajor ScrapMaster is equipped with an approved air gap, eliminating the need for vacuum breakers. The Uniform Plumbing Code states that air gaps are accepted as replacements for vacuum breakers with food waste disposing systems.

NOTE: To assure against leaks, tighten water harness fittings. They may come loose during shipment, fabrication or installation. Pressure regulators should be installed in areas where water pressure exceeds the recommended maximum of 80 psi.

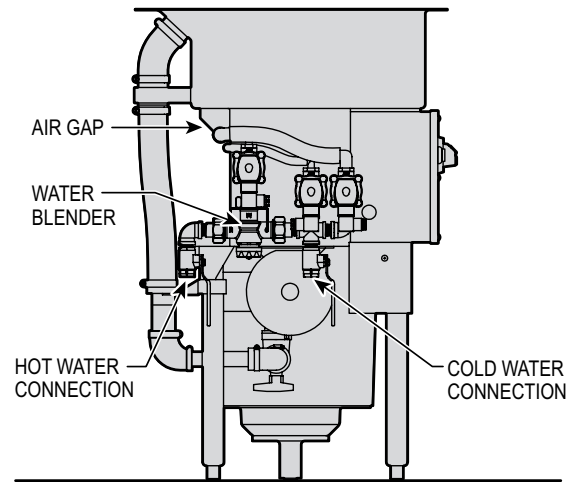

MAKE ALL PLUMBING CONNECTIONS IN ACCORDANCE WITH NATIONAL AND LOCAL PLUMBING CODES.

DRAIN PIPING

There are two (2) drain connections to be made on the ScrapMaster system. The ScrapMaster reservoir tank drain is supplied with a simple quick-opening drain valve using a 2" rubber coupler to connect to your 2" drain pipe. 3" piping is recommended for the disposer drain. These two (2) drain lines can be run separately to floor drains or can be tied together using a WYE and/or a sanitary tee fitting if space allows.

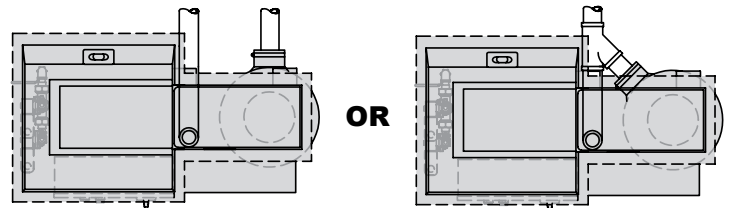

Electrical

ELECTRICAL

The Salvajor ScrapMaster is designed for easy electrical installation. Internal components such as the pump motor, solenoids, separator motor, etc. are all factory pre-wired. The field wiring on the ScrapMaster consists of two (2) simple steps.

First, wire from the disposer to the 1/2" knockout provided for you on the control panel that is located on the front of the ScrapMaster.

Second, run power from the power source to the control panel. A 1/2" knockout is provided on the water harness side of the control panel.

Complete wiring diagrams will be found inside the ScrapMaster control panel. The disposer wiring diagram will be found attached to the junction box cover located on the bottom of the disposer, as well as in the disposer installation manual.

IMPORTANT:

The pump and separator must be checked for proper rotation.

NOTE: The ScrapMaster is equipped with a safety lid switch which is located at the safety cover over the disposer. The safety lid switch is activated whenever the disposer safety cover is out of place, cutting power to the ScrapMaster system.

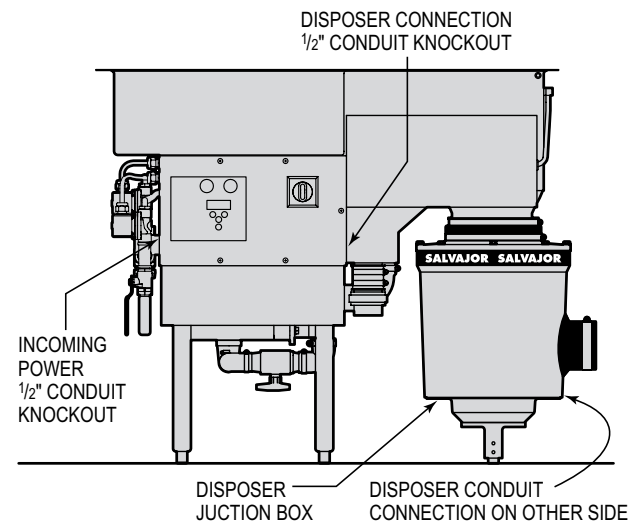

ALWAYS USE WATERTIGHT CONDUIT AND FITTINGS WHEN WIRING THIS PRODUCT.

MAKE ALL CONNECTIONS IN ACCORDANCE WITH LOCAL AND NATIONAL ELECTRICAL CODES.

FULL LOAD AMPS				
TOTAL FULL LOAD AMPS			THREE PHASE	
MODEL	208V	230V	460/480V	Total HP
300-SM/PSM	12.64	11.66	5.83	3.92
500-SM/PSM	17.64	16.16	8.13	5.92

Operating Instructions

TO START:

- 1 Close DRAIN VALVE.
- 2 Position RESERVOIR SCREENS in bottom of tank.
- 3 Position SALVAGE BASIN over reservoir screens.
- 4 Lower SAFETY COVER over disposer.
- 5 Press START button on CONTROL PANEL.
(See HydroLogic Control Operating Instructions below.)
- 6 Adjust WATER PLUME VALVE. Recommended plume height 4" - 6".

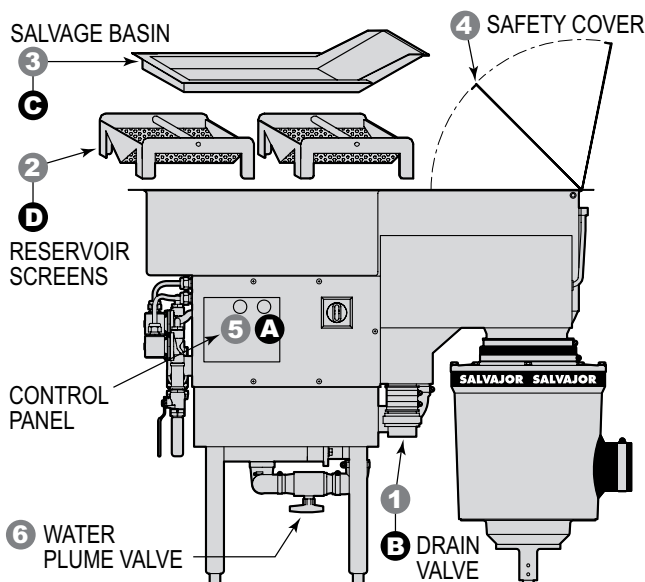

TO STOP:

- A Press STOP button on the CONTROL PANEL.
- B Open DRAIN VALVE.
- C Remove and drain SALVAGE BASIN.
- D Remove RESERVOIR SCREENS from tank.

Do not dump waste in tank.

Rinse SALVAGE BASIN, SCREENS, tank interior and separator discs thoroughly.

HydroLogic® Control Operating Instructions

- 1 Press the START button to begin operation. *Note: If the Line Disconnect is in the OFF position it will need to be turned to the ON position.*
 - Display will read "TANK FILL DELAY" *.
 - The pump then starts.
- 2 Choose from 2 modes of operation.

On/Off Mode - Display reads "SYSTEM ON". Unit will run until turned off.

Water Saver Mode - Press ON/OFF to activate. The blue light will illuminate and the display will read "SYSTEM ON". Unit will run at a normal flow rate until the operator leaves. If the operator leaves, the display will read "RUN TIME" and a timer will start. The unit will run at a reduced flow rate until the operator returns or the run timer reaches 0:00. The unit will turn off when the run timer reaches 0:00. To increase or decrease the run time, use the + and - buttons to adjust to the desired run time. If the operator returns before the run timer reaches 0:00, the unit returns to normal operation and the run timer will reset.

*Note: An * appears in the upper left corner of the display when the operator is in range of the sensor.*

- 3 Press the STOP button to end all operations.

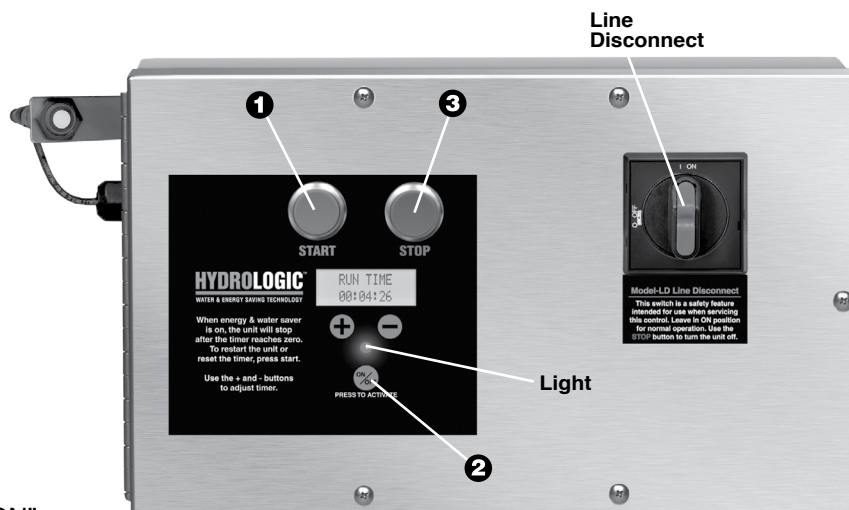

U.S. Pat. No. 7,815,134

Troubleshooting

WARNING! DISCONNECT THE POWER TO THE SYSTEM BEFORE SERVICING.

This troubleshooting guide is to provide basic checks to facilitate problem isolation and repair. All repairs should be made according to local codes and by a qualified technician.

PROBLEM	POSSIBLE CAUSE	SOLUTION
Machine will not turn on.	Line disconnect turned to off position.	Turn disconnect on.
	Door open over disposer.	Close door.
	Proximity switch inoperative.	Replace switch.
Tank will not fill up.	Drain open.	Close slip valve.
	Door open over disposer.	Close door.
Only hot or cold water is going into tank.	Hot or cold valve closed.	Open valves.
	Blender is not working or is out of adjustment.	Replace blender. Adjust setting of blender.
Pump motor not running.	Door open over disposer.	Close door.
	Overload tripped.	Wait for overload to cool and check for cause of reset to trip, i.e. debris in pump.
	Proximity switch inoperative.	Replace switch.
	Pump motor inoperative.	Replace pump motor.
Water leaks from pump.	Pump seal/o-ring worn.	Replace seal/o-ring.
	Clamps loose.	Tighten clamps.
Food is not moving over the separator into the disposer.	Gearmotor is not turning.	Check gearmotor and replace if bad.
	Gearmotor is running backwards.	Reverse rotation of motor.
Sensor does not detect operator leaving work area.	Object blocking sensor.	Remove object from in front of sensor.
	Water Saver not turned on.	Turn on Water Saver.
	Dirty sensor.	Clean sensor.

IMPORTANT! Do NOT use corrosive chemicals for scrapping or cleaning purposes!

How it Works

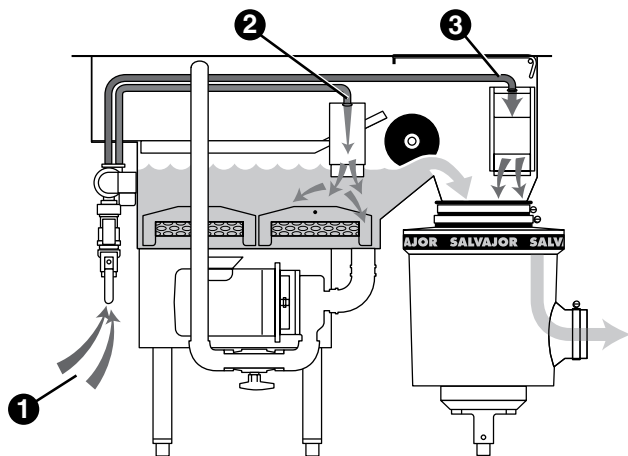

- 1 Hot and cold water pass through a water blender set at 107° F.
- 2 The blended water enters the tank at the rate of 5 gallons per minute.
- 3 Cold water is introduced directly into the disposer grind chamber at the rate of 2 gallons per minute.

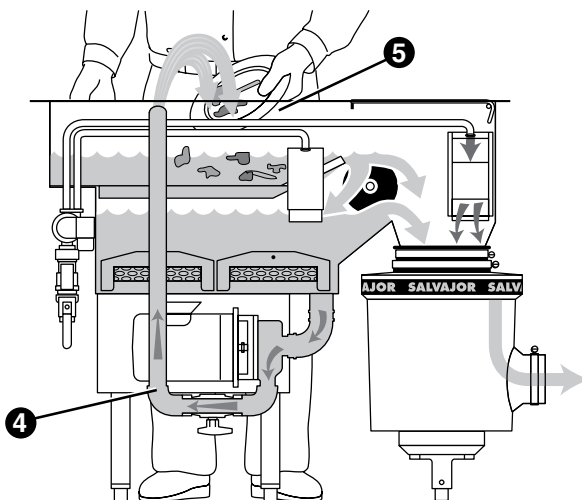

- 4 The ScrapMaster pump recirculates water through the gusher tube.
- 5 As dishes are passed through the water plume, they are scrapped and pre-rinsed at the same time.

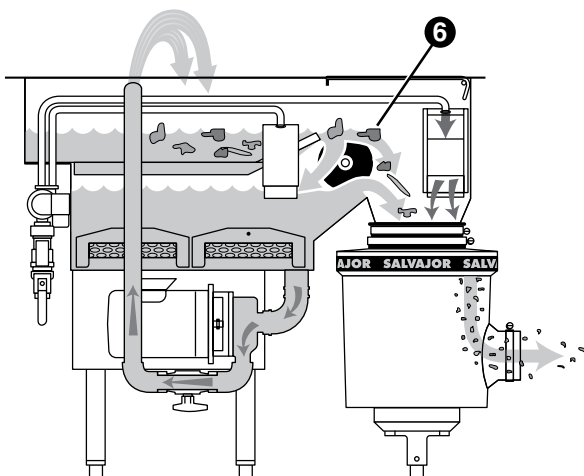

- 6 Water falls through the separator and returns to the tank reservoir while the waste falls into the disposer.

Salvajor Warranty

ONE YEAR PARTS AND LABOR

Equipment covered by this warranty:

All Salvajor commercial disposers, disposer systems, collector systems, accessories and parts.

Length of this warranty:

Parts and labor for 12 months from date of installation or 15 months from date of shipment from the factory, whichever expires first, on all disposers and systems. Accessories manufactured by Salvajor are covered for parts and labor when they are sold as part of the original disposer assembly or system package. Accessories not manufactured by Salvajor are covered for parts only. Accessories and parts sold separately are covered for parts and/or workmanship for 90 days from date of installation.

Warranty coverage:

Providing the equipment is unaltered, has been properly installed, maintained and operated, Salvajor will repair or replace at no cost, defective parts due to material or workmanship, if such service is performed by a Salvajor Authorized Service Center. Parts wear is not considered a defect.

Conditions not covered by this warranty:

Faulty or improper electrical installations, faulty or improper plumbing installations, disposer jammed by foreign object, tripped overload (re-set button), clogged drains, pump jams, clogged solenoid valves, blown fuses, abuse, accidental damage, unit improperly sized for application according to factory recommendations.

This warranty is limited to the continental United States, Hawaii and Canada.

*For your nearest
Factory Authorized Service Center:
Call 1-888-SALVAJOR
or 816-363-1030
Fax 1-800-832-9373
or 816-363-4914
www.salvajor.com
service@salvajor.com*

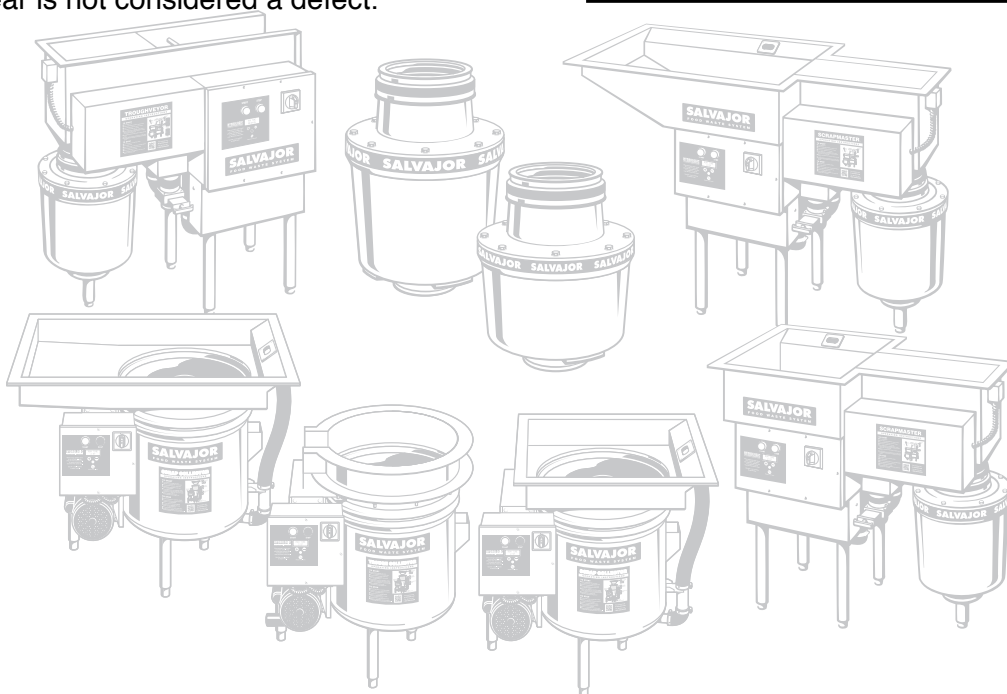

GENERAL TERMS AND CONDITIONS OF SALE

These Terms and Conditions shall govern the transaction by and between The Salvajor Company (herein referred to as the "Seller") and the customer or person or entity purchasing goods ("Goods") from Seller (therein referred to as "Buyer"), together with any quotation or acknowledgment from Seller relevant to the sale of the Goods and all documents incorporated by specific reference therein, and shall constitute the complete and exclusive agreement governing the sale of Goods by Seller to Buyer. Buyer's acceptance of the Goods will manifest Buyer's assent to these Terms and Conditions.

1. PRICES

Unless otherwise specified in writing by Seller, Seller shall have the right to change the price for the Goods to Seller's price for the Goods at the time of shipment. All prices are exclusive of taxes, transportation and insurance which are to be borne by Buyer.

2. TAXES

All taxes or government charge (or increase in same) affecting Seller's costs or which seller is otherwise required to pay or collect in connection with the sale, purchase, delivery, storage processing, use or consumption of Goods shall be for Buyer's account and shall be added to the price.

3. TERMS OF PAYMENT

Net 30 days invoices will bear the date on which shipment is made and terms are based upon date of shipment and not on date of arrival. Seller shall have the right among other remedies, to terminate or suspend performance under any order, if Buyer fails to make any payment when due. Buyer shall be liable for all expenses, including attorney's fees, relating to the collection of past due amounts. Delinquent payments shall bear interest at a rate to be determined by Seller, which shall not exceed the legal maximum rate, from the date due until paid. Should Buyer's financial responsibility become unsatisfactory to Seller, Seller may require cash payments or satisfactory security.

4. SHIPMENT AND DELIVERY

Deliveries are made F.O.B. Seller's shipping point. Risk of loss or damage and liability therefore shall pass to Buyer upon delivery to carrier. Shortages or damages must be acknowledged and signed for at the time of delivery. While Seller will use all reasonable commercial efforts to maintain the delivery date (s), all shipping dates are approximate and not guaranteed. Seller reserves the right to make partial shipments. If the shipment of the Goods is postponed or delayed by Buyer for any reason, Buyer agrees to reimburse Seller for any and all storage costs and other resulting expenses.

5. LIMITED WARRANTY

Subject to the limitations of Section 6 Seller warrants that the Goods manufactured by Seller will be free from defects in material and workmanship and meet Seller's published specifications at the time of shipment under normal use and regular service and maintenance for a period of one year from the date of shipment of the Goods by Seller unless otherwise specified by Seller in writing. Products purchased by Seller from a third party for resale to Buyer ("Resale Products") shall carry only the warranty extended by the original manufacturer whether or not the component is incorporated in goods sold by the Seller.

The warranties provided herein are the sole and exclusive warranties by seller with respect to the goods and are in lieu of and exclude all other warranties, express or implied arising by operation of law or otherwise, including without limitation, merchantability and fitness for a particular purpose whether or not the purpose or use has been disclosed to seller in specifications drawings or otherwise and whether or not seller's products are specifically designed and/or manufactured by seller for Buyer's use or purpose.

These warranties do not extend to any losses or damages due to misuse, accident, abuse, neglect, normal wear and tear, Buyer's negligence, unauthorized modification or alteration use beyond rated capacity, or improper installation, maintenance or application. To the extent that Seller has relied upon any specifications, information representation or operating conditions or other data supplied by Buyer or its agents to Seller in the selection or design of the Goods and the preparation of Seller's quotation, and in the event that actual operating conditions or other conditions differ from those represented by Buyer and relied upon by Seller, any warranties or other provisions contained herein which are affected by such conditions shall be null and void.

If within thirty (30) days after Buyer's discovery of any nonconformity with warranty within the warranty period, Buyer notifies Seller thereof in writing, Seller shall, at its own option repair, correct or replace F.O.B. point of manufacture, that portion of the nonconformity. Failure by Buyer to give such written notice within the applicable time period shall be deemed an absolute and unconditional waiver of Buyer's claim for such nonconformity. Goods repaired or replaced during the warranty period shall be covered by the foregoing warranties for the remainder of the original warranty period or ninety (90) days, whichever is longer.

Buyer assumes all other responsibility for any loss, damage, or injury to persons or property arising out of connected with or resulting from the use of Goods, either alone or in combination with other products/components.

6. LIMITATION OF REMEDY AND LIABILITY

The sole and exclusive remedy for breach of any term or condition or warranty hereunder (other than the warranty provided under Section 7) shall be limited at Seller's option to repair, correction or replacement under Section 5 or refund of the purchase price. Seller shall not be liable for damages caused by delay in performance and in no event, regardless of the form of the claim or cause of action (whether based in contract, infringement, negligence, strict liability, other tort or otherwise) shall Seller's liability to Buyer and/or its customers exceed the price paid by Buyer for the specific goods provided by Seller giving rise to the claim or cause of action.

Buyer agrees that in no event shall seller's liability to buyer and/or its customers extend to include incidental, consequential or punitive damages. The term consequential damages shall include without limitation loss of anticipated profits business interruption loss of use or revenue, cost of capital or loss or damage to property or equipment.

It is understood that any technical advice furnished by Seller with respect to the use of the Goods is given without charge and Seller assumes no obligation or liability for the advice given, or results obtained, all such advice being given and accepted at Buyer's risk.

7. PATENTS AND COPYRIGHTS

Subject to the limitations of the second paragraph of Section 6, Seller warrants that the Goods sold except as are made specifically for Buyer according to Buyer's specifications do not infringe any valid U S patent or copyright in existence as of the date of shipment. This warranty is given upon the condition that Buyer promptly notify Seller of any claim or suit involving Buyer in which such infringement is alleged and, that Buyer cooperate fully with Seller and permit Seller to control completely the defense settlement or compromise of any such allegation of infringement. In the event such Goods are held to infringe such a U S patent or copyright in such suit, and the use of such Goods is enjoined, or in the case of a compromise or settlement by Seller, Seller shall have the right, at its option and expense to procure for Buyer the right to continue using such Goods or replace them with non-infringing Goods, or modify same to become non-infringing, or grant Buyer a credit for the depreciated value of such Goods and accept return of them.

8. EXCUSE OF PERFORMANCE

Seller shall not be liable for delays in performance or for non-performance due to acts of God, acts of Buyer, war, fire, flood, weather, sabotage, strikes, or labor or civil disturbance, government requests, restrictions, laws, regulations, orders of actions, unavailability of or delays in transportation, default of suppliers, or unforeseen circumstances or any event or causes beyond Seller's reasonable control Deliveries or other performance may be suspended for an appropriate period of time or canceled by Seller upon notice to Buyer in the event of any of the foregoing, but the balance of the agreement shall otherwise remain unaffected as a result of the foregoing. If Seller determines that its ability to supply the total demand for the Goods or to obtain material used directly or indirectly in the manufacture of the Goods is hindered, limited or made impracticable due to causes set forth in the preceding paragraph, Seller may allocate its available supply of the Goods or such material (without obligation to acquire other supplies of any such Goods or material) among itself and its purchasers on such basis as Seller determines to be equitable without liability for any failure of performance which may result therefrom.

9. CANCELLATION

Seller may cancel this agreement at any time for any reason upon 30 days written notice. Unless otherwise agreed in writing by Seller, Buyer may not cancel this agreement for any reason.

10. CHANGES

Buyer may request changes or additions to the Goods consistent with Seller's specifications and criteria. In the event such changes or additions are accepted by Seller, Seller may revise the price and dates of delivery. Seller reserves the right to change designs and specifications for the Goods without prior notice to Buyer, except with respect to Goods being made-to-order for Buyer.

11. ASSIGNMENT

Buyer shall not assign its rights or delegates its duties hereunder or nay interest therein or any rights hereunder without the prior written consent of the Seller, and any such assignment without such consent, shall be void. Seller may assign its rights and delegate its duties hereunder.

12. GENERAL PROVISIONS

These terms and conditions supersede all other communications, negotiations and prior oral or written statements regarding the subject matter of these terms and conditions. No change, modifications, rescission, discharge, abandonment, or waiver of these terms and conditions shall be binding upon the Seller unless made in writing and signed on its behalf by a duly authorized representative of the Seller. No conditions, usage or trade, course of dealing or performance, understanding, or agreement purporting to modify, vary, explain, or supplement these terms and conditions shall be binding unless hereafter made in writing and signed by the party to be bound and no modification shall be affected by the Seller's receipt, acknowledgment, or acceptance of purchase orders, shipping instruction forms, or other documentation containing terms at variance with or in addition to those set forth herein. No waiver by either party with respect to any breach or default or of any right or remedy and no course of dealing, shall be deemed to constitute a continuing waiver of any other breach or default or of any other right or remedy, unless such waiver be expressed in writing and signed by the party to be bound. All typographical or clerical errors made by Seller in any quotation, acknowledgment or publication are subject to correction.

The validity, performance and all other matters relating to the interpretation and effect of this agreement shall be governed by the law of the state of Missouri. Buyer and Seller agree that the proper venue of all actions arising in connection herewith shall be only in the state of Missouri. The Convention for the International Sales of Goods shall not apply to this agreement.

13. COMPLIANCE WITH CERTAIN LAWS

These Goods shall be produced in compliance with the requirements of the Fair Labor Standards Act of 1938, as amended and Executive Order 11246.