



BEVERAGE-AIR

Project: _____	AIA#
Item: _____	
Location: _____	SIS#
Approved: _____	

TMF2HC TOP MOUNT REACH-IN FREEZER

TOP MOUNT REACH-IN FREEZER

TMF2HC Reach-In Freezer
Hydrocarbon Series

MODEL:
TMF2HC-1S



4 Year Parts/Labor Warranty Available
7 Year Compressor Warranty

CABINET CONSTRUCTION

- Intelligent temperature control reduces energy consumption
- Three (3) shelves per section
- Door locks
- Stainless steel exterior and interior
- Easy access to the refrigeration system
- 6" Heavy-duty casters, two (2) with brakes
- Energy efficient LED lights
- Fill mark helps to prevent overpacking



ACCESSORIES

- 2 Year parts/labor standard, additional 2 year warranty available
- Additional shelves

REFRIGERATION SYSTEM

- Uses environmentally friendly, energy efficient R290 refrigerant, and meets all regulatory requirements for CARB, SNAP, DOE & more
- Hot gas condensate evaporator and face heater
- Electric defrost heater
- Coated evaporator coil
- Freezer capable of maintaining product temperatures of 0°F and below



Please verify qualifying units by visiting:
www.energystar.gov/cfs

3779 Champion Blvd., Winston-Salem, NC 27105
1-888-845-9800 Fax: 1-336-245-6453
Beverage-Air.com Sales@bevair.com



BEVERAGE-AIR

MODEL	TMF2HC-1S
EXTERNAL DIMENSIONAL DATA	
Width Overall	53 3 ¹ / ₂ "
Depth Overall	33 9 ¹ / ₁₆ "
Height Overall	80 1 ¹ / ₂ "
Number of Doors	2
INTERNAL DIMENSIONAL DATA	
NET Capacity (cubic ft.)	40
Internal Width Overall (in)	50 7 ¹ / ₂ "
Internal Depth Overall (in)	28 3 ¹ / ₂ "
Internal Height Overall (in)	56 3 ¹ / ₂ "
Number of Shelves	6
ELECTRICAL DATA	
Full Load Amperes 115/60/1	8.3
REFRIGERATION DATA	
Horsepower	(2X) 1/2
Capacity (BTU/Hr)	3660
Heat Rejection (BTU/Hr)	5490
Charge (lbs/grams)	0.1543/70
SHIPPING DATA	
Gross Weight (crated lbs)	646 lbs
Height - Crated	81"
Width - Crated	56"
Depth - Crated	35"

Top Mount Reach-In Freezer Model: TMF2HC-1S

Model Views

Required Clearance: Top 12", Rear 3", Side 0"

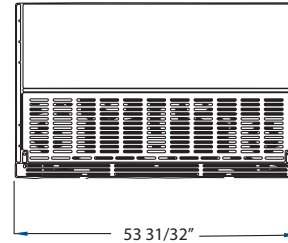

PLAN VIEW

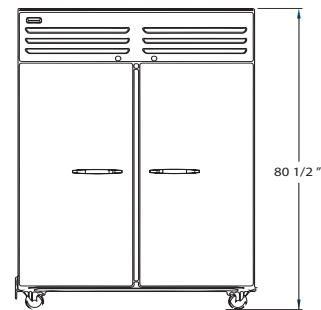

ELEVATION VIEW

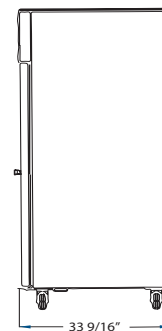

SIDE VIEW

ELECTRICAL CONNECTION



115/60/1
NEMA 5-15P

Unit pre-wired at factory and include 9.8' long cord and plug set.



3779 Champion Blvd., Winston-Salem, NC 27105 1-888-845-9800 Fax: 1-336-245-6453 Beverage-Air.com Sales@bevair.com

an Ali Group Company



The Spirit of Excellence