

MEDALLION PROFESSIONAL

36" THERMOSTATICALLY CONTROLLED GRIDDLE TOP RANGE WITH STANDARD OVEN

STANDARD FEATURES

- Stainless steel front and sides STANDARD
- 6" (152mm) chrome steel adjustable legs
- Adjustable stainless steel front rail 6-1/16" (154mm) to 7-5/8" (194mm)
- Three (3), 30,000 BTU/ea (8.79 kW), "H-Types" Cast-Iron
- burners Total of 90,000 BTU (26.37 kW) One (1) Single Standing Pilot per burner for automatic ignition
- 2-5/16" (58.74 mm) high welded steel side and back splash guards
- Each burner-Thermostatically controlled
- 1-1/4" (31.75 mm) thick Blanchard Ground steel griddle plate.
- Removable 1-1/2 gallon Large Capacity Grease Can with integrated Slide Off Cover
- Full width 3" (76.2 mm) wide grease gutter
- Piezo spark ignition for oven, and a porcelainized oven interior
- 1-1/4" NPT front manifold
- Stainless steel burner box section
- 40,000 BTU, (11.72 kW), cast iron oven burner. 30,000 BTU (8.8kW), tubular shaped aluminized steel Convection Oven burner
- Oven Thermostat (temp range: 150°F to 500°F)
- Storage base interior is aluminized steel
- One year limited parts & labor warranty (USA and Canada only)

OPTIONAL FEATURES

- Stainless steel back rear panel
- Stainless steel common front rail up to 68" (1728mm) wide, (No additional charge)
- Stainless steel oven interior
- Additional oven rack
- Rear gas connection, on select models 3/4" or 1" NPT
- End caps and cover (no charge)- Must specify
- Polyurethane non-marking swivel casters (2) w/front brakes
- Toe base (not for use with "C" oven base)
- Storage base shelf-aluminized or stainless steel
- Single deck stainless steel high shelf
- Double deck stainless steel high shelf
- 10" (254 mm), 17" (432mm) 22.375" (568mm) 34.375" (873mm) high stainless steel backguard
- Stainless steel vertical flue riser, 13"W x 34.375"H, (330mm x 873mm)
- Grooved Griddle 17"
- Griddle Top Combination 40,000 BTU/ea (11.72 kW)
- 23" Griddle Top Combination-30,000 BTU/ea (8.79 kW) 34-IHT, (-2)



AMERICAN RANGE

CHEF INSPIRED, PROFESSIONAL COOKING EQUIPMENT



Optimized Engineering



Model Shown HD36-36TG-I

Shown with optional background



Optimized Engineering

SHORT FORM SPECIFICATIONS:

The Medallion Professional O.E. (Optimized Engineering) Heavy-Duty Series by American Range is the crème de la crème in commercial cooking equipment. Designed for the professional chef in high demanding/continuous use operations. Our Medallion Professional O.E. Series offers advanced innovation and technology to deliver unprecedented cooking performance and experience.

Model: **HD36-36TG-I**, Heavy-Duty Medallion Professional O.E. Series, gas powered **36" Thermostatically Controlled Griddle Top Range with Standard Oven**. Includes stainless steel front and sides with 6" chrome legs (unless otherwise specified). Three (3) **Power-Max** 30,000 Btu/hr. H-Type cast iron burners. Total of 90,000 Btu/hr. cooking surface. Heavy-duty Blanchard Ground 1-1/4" thick griddle plate with a Snap Action thermostat with 150oF to 500oF temperature range. Includes a 3" wide 1-1/2 Gallon grease can with integrated slide-off lid. Unit to be 34" (864mm) wide and 38" (965mm) deep with telescoping front rail fully extended to a maximum of 7-5/8" (194mm). Specify Natural gas (NG) or Liquid Propane gas (LP). ETL listed. Available options include Convection Oven-Model: HD64-36TG-IC, Storage Base with removable hinged double doors-Model: HD36-36TG-0, or as a Modular Top-Mode: HD36-36TG-M).

36" THERMOSTATICALLY CONTROLLED GRIDDLE TOP RANGE WITH STANDARD OVEN

Standard oven / Convection oven Storage base / or Modular top
HD36-36TG-I, HD36-36TG-IC, HD36-36TG-O, HD36-364TG-M

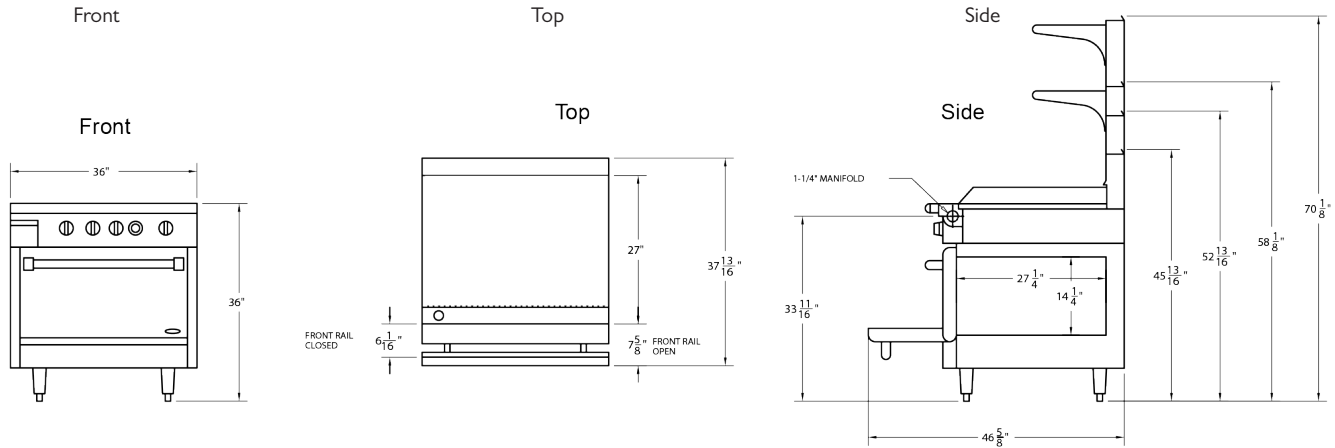

EXTERIOR DIMENSIONS

Model#	HD36-36TG-I (C)	HD36-36TG-O	HD36-36TG-M
Width	36"/914mm	36"/914mm	36"/914mm
Depth	38"/965mm (Rail out Dim)	38"/965mm (Rail out Dim)	38"/965mm
Height w/NSF legs	36"/914mm	36"/914mm	36"/914mm(w/stand)
Height Less NSF Legs	30"/762mm	30"/762mm	8"/203mm (less stand)

STORAGE OVEN/CONVECTION OVEN/STORAGE BASE INTERIOR

Width	26-1/4"/667mm	30-1/2"/775mm	N/A
Depth	27-1/4"/692mm**	30"/762mm	N/A
Height	14-1/4"/362mm	20"/508mm	N/A
Weight (LB/KG)	510/230	410/186	320/145

** (C) Oven is 23" (584 mm) Deep

INPUT-Btu/hr (N-Gas)	HD36-36TG-I	kW Equivalent	HD36-36TG-O	KW Eq	HD36-36TG-M	kW Equivalent
Top Burner	90,000	26.37	90,000	26.37	90,000	26.37
(37,000BTU/ea)	40,000	11.72	N/A	—	N/A	—
TOTAL	130,000	38.09	90,000	26.37	90,000	26.37

I = Oven / C=Convection Oven (30,000BTU/ea) / O= Storage Base / M= Modular Top

Installation Notes:

Combustible Wall Clearances

Sides: 6" (152mm)

Back: 6" (152mm)

For reduced clearances, refer to ANSI Z223.1/NFPA #54 and CAN/CGA B149.

Entry Clearance:

Crated: 39-1/4" (997mm)

Uncrated: 34-1/4" (870mm)

Manifold Pressure:

Natural 6 W.C. (15 mbar)

Propane 10 W.C. (25 mbar)

NOTE: Data applies only to North America.

Gas Input Ratings shown here are for installations up to 2,000 ft. (610m) above sea level. Specify altitudes over 2,000 ft.

Commercial cooking equipment requires an adequate ventilation system. For additional information, refer to the National Fire Protection Association's standard NFPA96 "Vapor Removal from Cooking Equipment." (NOTE: For North America only)

Electrical characteristics each (1C) oven: 1/4 HP motor, 120 VAC, single phase, 2.8 amps, (6-foot power supply cord provided). 230 VAC export is direct connect, single phase, 50Hz.

Please specify gas type when ordering.



Because of continuing product improvement these specifications are subject to change without notice.

