

MODEL: IRR-AGB49

REACH-IN:
Top Mounted Reach-in Refrigerators



DOE COMPLIANT

General Strengths

- ✓ **Energy efficiency higher.** R290 refrigerant with electric fans, LED lighting and evaporative tray without electric resistances
- ✓ **Sanitation.** The interior cabinet is built with rounded corners (extensive radius for easy cleaning). Quick ability to take off shelves and slides for interior cleaning. Each cabinet has a drain at the bottom of the unit. When cleaning the unit make sure the drain hose is routed to a floor drain.
- ✓ **Doors.** Self-closing door system with permanent pressure. Stay open feature included when door remains open after 95 degrees. All doors include triple chamber door gaskets, easy to remove and snap in.
- ✓ **Control systems.** Greater ability for the adjustment of temperature range as per the end user's requirements.
- ✓ **100% Tested.** All condenser units are 100% tested, in helium chambers for refrigerant leak detections.
- ✓ **Certified.** Audited and Certified by INTERTEK for compliance with UL 471 and NSF 7. AENOR audited and certified by internationally recognized firm. ISO 9001:2008 (Quality); ISO 14001:2004 (Environmental); OSHAS 18001:2007 (Prevention and Worker Safety)
- ✓ **Lighting.** LED lighting in the canopy and cabinet sides reduces the energy consumption by 80% to 90% compared to a traditional bulb, better light quality.

MODEL	Dimensions (inches) (mm)			Nº Doors	Nº Shelves	Ref.	Ref. Weight (Lbs.) (gr.)	Temp. Range (°F) (°C)	Capacity (Cu. Ft.) (L)	Cond. Unit. H.P.	Case Amps 115 V.	Crated Weight (Lbs.) (Kg.)
	W	D	H									
IRR-AGB49	54-1/2	31-1/4	84	1	6	R290	0.31	28°F/46°F	49	1/3	3.9	620
	1384	794	2125									

ETL LISTED TO UL471 STANDARD AND SANITATION CLASSIFIED TO NSF7 – WE RESERVE THE RIGHT TO CHANGE SPECIFICATIONS WITHOUT PRIOR NOTICE

MODEL: IRR-AGB49
**REACH-IN:
Top Mounted Reach-in Refrigerators**
STANDARD FEATURES
➤ Exterior

- AISI 304 Stainless Steel.

➤ Interior

- AISI 304 Stainless Steel,
- Sealed interior floors and rounded cabinet corners,
- LED lighting,
- Internal drain plugs for easy cleaning.

➤ Doors

- Polyurethane insulated door,
- Self closing door with stay open feature,
- Stainless Steel heavy-duty hinges,
- Triple chamber snap in door gaskets for easy removal and cleaning,
- Door locks,
- Full-height door opening: 23"x53" (584x1346 mm).

➤ Insulation

- CFC-Free polyurethane insulation, entire cabinet structure is foamed-in using a high-density polyurethane insulation,
- Low GWP & Zero ODP effect.

➤ Casters

- 4" diameter casters.
- Locks provided on front set.

➤ Shelving

- (3) Three plastic coated wire shelves per door with stainless steel tray slides included,
- Dimensions WxD: 20-7/8"x25-5/8" (530x650 mm),
- Tray slides are compatible with 18"x26" (457x660 mm) and 12"x20" (305x660 mm) sheet pans,
- (3) Three plastic coated tray dividers,

➤ Refrigeration

- Digital temperature controller with automatic defrost system,
- Hinged control panel, easy-removable,
- **Compact refrigeration system monoblock, INFRIBLOCK®**,
- Energy-saving non-electric condensate pan,
- Evaporator coil coated with anti-corrosion material 100% Polyester,
- Forced air refrigeration system,
- Expansion valve,
- Electric fans,
- Refrigeration capacity: 2245 Btu/h (14°F) / 658 W (-10°C).

➤ Electrical

- Cord and NEMA 5-15P plug,
- Electrical connection is 115V / 1ph / 60 Hz.
- 15 AMP breakers required,

➤ ETL Listed to UL471 Standard and Sanitation classified to NSF7.
OPTIONAL FEATURES

- ✓ Stainless Steel wire shelf,
- ✓ Additional slide kits,
- ✓ Set of 6" legs, height adjustable from 5" to 8",
- ✓ Electrical connection is: 230V / 1ph / 50 Hz (plug type varies).

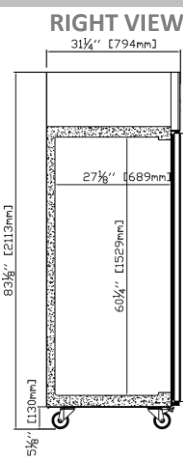
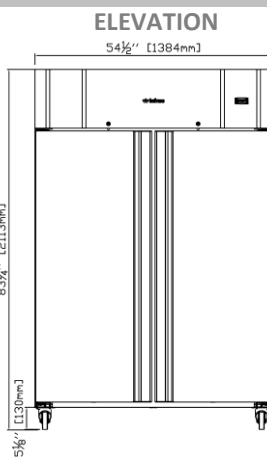
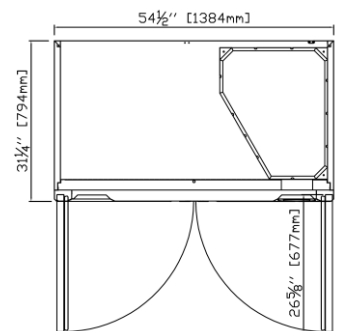
PLAN VIEW

PLAN VIEW

ETL LISTED TO UL471 STANDARD AND SANITATION CLASSIFIED TO NSF7 – WE RESERVE THE RIGHT TO CHANGE SPECIFICATIONS WITHOUT PRIOR NOTICE