



PROJECT: _____

ITEM NO: _____

QUANTITY: _____

Stainless Steel Dish Cabinet

FEATURES & CONSTRUCTION:

- Top is fabricated with 1-1/2" rounded front edge and flat edge on rear and both ends.
- Cabinet top front edge formed with hemmed edge to provide extra rigidity and safe to touched finish.
- Reinforced cabinet top with sound deadening hat channels.
- Middle Shelf is adjustable via built-in stainless steel pilasters or can be removed.
- All exposed welded areas smooth polished to brush finish sanitary #4.
- All cabinets shipped K.D. but easily assembled.

MATERIAL:

TOP: 16 Gauge Stainless Steel - 304
 BODY: 18 Gauge Stainless Steel - 304
 MIDDLE SHELF: 18 Gauge Stainless Steel - 304
 LEG: Stainless Steel with 1" Adjustable
 Stainless Steel Bullet Feet



NSF STD.2
 Certified

MODEL#	UNIT SIZE		
	L	D	H
SMDC-1536	36"	15"	35-1/2"
SMDC-1548	48"		
SMDC-1560	60"		
SMDC-1572	72"		



SMDC-1548

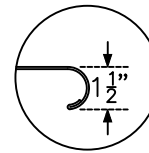

Rolled Rim Top
 Front Reinforced
 with Hemmed
 Edge

MODEL#	UNIT SIZE		
	L	D	H
SMDC-2418	18"	24"	35-1/2"
SMDC-2430	30"		
SMDC-2436	36"		
SMDC-2448	48"		
SMDC-2460	60"		
SMDC-2472	72"		



SMDC-2448

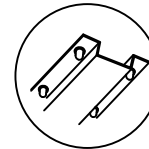

Two (three on 30" deep)
 Hat Channel Supported.
 Attached to Underside of
 Top via Studs Welded to
 Underside of Top, Adhesive
 and Stainless Steel Acorn
 Nuts.

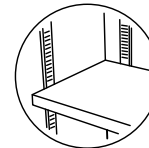

Stainless Steel Pilasters
 Allows for Adjustable
 Middle Shelf

MODEL#	UNIT SIZE		
	L	D	H
SMDC-3018	18"	30"	35-1/2"
SMDC-3030	30"		
SMDC-3036	36"		
SMDC-3048	48"		
SMDC-3060	60"		
SMDC-3072	72"		



SMDC-3048



Stainless Steel
 Bullet Feet
 1" Adjustable



SAPPHIRE MANUFACTURING
 Tel: 718-543-2111
 Fax: 718-543-2121

info@sapphiremanufacturing.com
 WWW.SAPPHIREMANUFACTURING.COM

Rev. 9/20



PROJECT

ITEM NO:

QUANTITY:

Stainless Steel Dish Cabinet



NSF STD.2
Certified

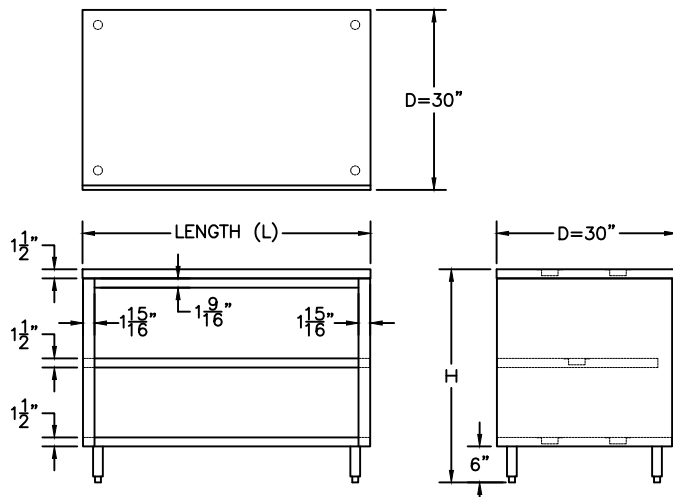
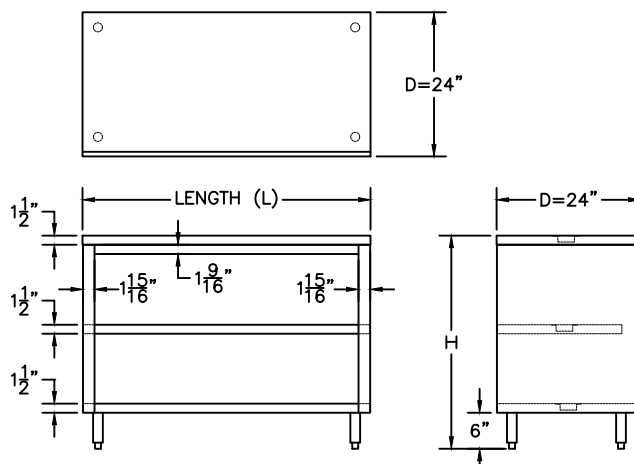
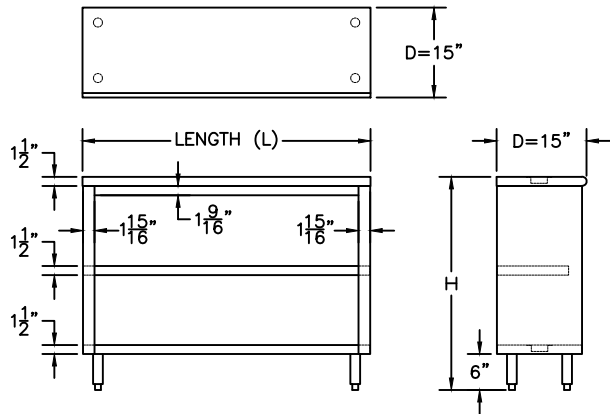

Specifications subject to change without notice.

All dimensions are typical (Tolerance 1/2").



SAPPHIRE MANUFACTURING
Tel: 718-543-2111
Fax: 718-543-2121

info@sapphiremanufacturing.com
WWW.SAPPHIREMANUFACTURING.COM

Rev. 9/20