



R-GNG-HPRO-4
Shown With
Options



R-GNG-LPRO-4
Shown With
Options

JOB _____ ITEM # _____ QTY # _____

MODEL NUMBER

- R-GNG-LPRO-3 R-GNG-HPRO-3
- R-GNG-LPRO-4 R-GNG-HPRO-4
- R-GNG-LPRO-5 R-GNG-HPRO-5
- R-GNG-LPRO-6 R-GNG-HPRO-6

CONSTRUCTION

Standard Grab-N-Go merchandisers will be built to the following specifications: The exterior shall be constructed of Matte Black, Moisture Resistant, Rigid PVC Composite Sheets. The interior cavity shall be stainless steel and lit with one top mounted LED light. The Unit shall use a self-contained forced-air refrigeration system and include stainless steel shelves with Black Price Tag Molding. Shelves shall be adjustable to 3 different angled positions. A Digital Refrigeration Control will be mounted in the front panel. Automatic Self Defrost shall be standard.

Model #	Description	Voltage	Amps	Plug	W	D	H	Remote Case BTU's Required
R-GNG-LPRO-3	Low Profile	120/60/1	19.1	NEMA 5-30P	36"	34-3/8"	56"	3500
		208/60/1	9.9	NEMA 6-15P				
R-GNG-LPRO-4	Low Profile	120/60/1	20.1	NEMA 5-30P	48"	34-3/8"	56"	5000
		208/60/1	14.3	NEMA 6-20P				
R-GNG-LPRO-5	Low Profile	208/60/1	15.8	NEMA 6-20P	60"	34-3/8"	56"	6500
R-GNG-LPRO-6	Low Profile	208/60/1	18.2	NEMA 6-30P	72"	34-3/8"	56"	8000
R-GNG-HPRO-3	High Profile	120/60/1	20	NEMA 5-30P	36"	34-3/8"	81-1/2"	4500
		208/60/1	11.9	NEMA 6-15P				
R-GNG-HPRO-4	High Profile	208/60/1	17.9	NEMA 6-30P	48"	34-3/8"	81-1/2"	6000
R-GNG-HPRO-5	High Profile	208/60/1	18.2	NEMA 6-30P	60"	34-3/8"	81-1/2"	7500
R-GNG-HPRO-6	High Profile	208/60/1	18.2	NEMA 6-30P	72"	34-3/8"	81-1/2"	9000

Option	Description
<input type="checkbox"/> APT	Aluminum Price Tag Molding
<input type="checkbox"/> BI	Black Powder Coat Interior
<input type="checkbox"/> B	Bumper
<input type="checkbox"/> NC	Roll Down Night Curtain
<input type="checkbox"/> LNC	Lockable Night Curtain (Adds 2" to Depth)
<input type="checkbox"/> R	Remote Deduct (No Condensing Unit)
<input type="checkbox"/> CSTR	Casters and Skirting (Adds 4" to height)
<input type="checkbox"/> LED	Add lighting to shelves
<input type="checkbox"/> C	Custom Laminate Color
<input type="checkbox"/> CI	Custom Powder Coated Interior Color
<input type="checkbox"/> SHD	Solid Hinged Doors - Rear (Adds 1-1/4" to Depth)

SPEC R-7

PIPER
The Food-Focused Equipment Company
www.piperonline.net

300 S. 84th Avenue
Wausau, WI 54401
Phone: 800-544-3057
Fax: 715-842-3125

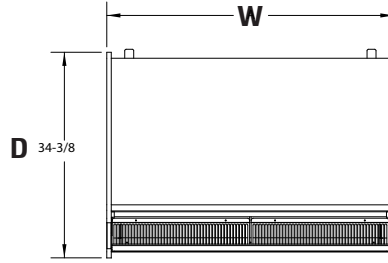

LOW PROFILE

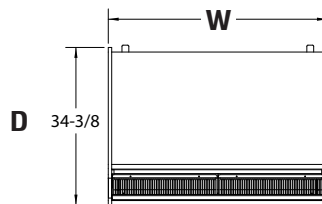
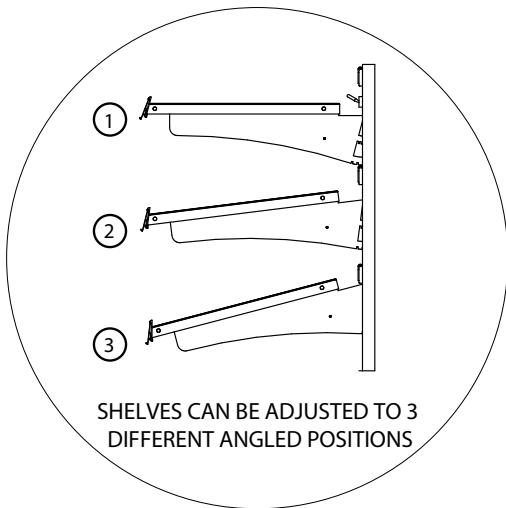
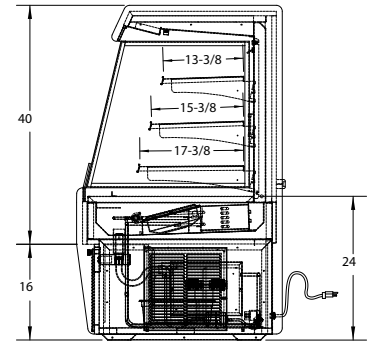
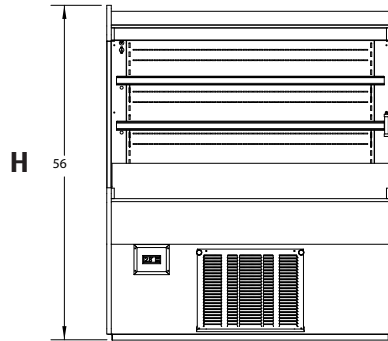

HIGH PROFILE

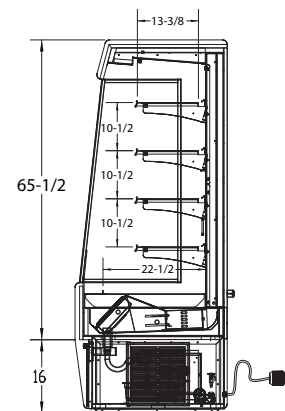
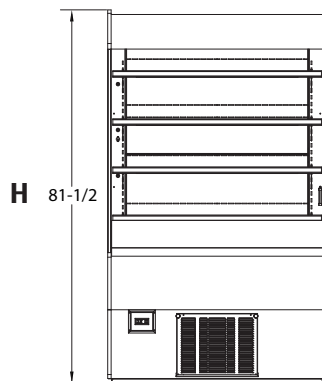

R-7 **SPEC**

PIPER
The Food-Focused Equipment Company
www.piperonline.net

300 S. 84th Avenue
Wausau, WI 54401
Phone: 800-544-3057
Fax: 715-842-3125

LIMITED WARRANTY: PIPER PRODUCTS warrants to the original purchaser parts and labor for a period of twelve (12) months from the date of purchase. See manufacturer's complete warranty for details.

It is our policy to build equipment which is design certified by companies that have been accredited at the Federal Level by the Occupational Safety and Health Agency (OSHA) and ANSI as a National Recognized Testing Laboratory. These companies include CSA International, Underwriters Laboratories, and the National Sanitation Foundation. However, a continuing program of product improvement makes it necessary to submit new models to the agencies as they are developed. Consequently, all models may not bear the appropriate labels at all times.

We reserve the right to change specifications and product design without notice. Such revisions do not entitle buyer to corresponding changes, improvements, additions or replacements for previously purchased equipment. Information is not for design purposes.